

# Experimental testing of school furniture designed with life-saving functions in case of earthquakes

Martina Sciomenta<sup>a</sup>, Gabriele Tamagnone<sup>b,\*</sup>, Laura Gioiella<sup>c</sup>, Fabio Micozzi<sup>d</sup>,  
Alessandro Zona<sup>c</sup>, Andrea Dall'Asta<sup>d</sup>, Massimo Fragiaco<sup>a</sup>

<sup>a</sup> University of L'Aquila, Department of Civil, Construction-Architecture & Environmental Engineering, L'Aquila, Italy

<sup>b</sup> LMGC, Univ. Montpellier, CNRS, Montpellier, France

<sup>c</sup> University of Camerino, School of Architecture and Design, Viale della Rimembranza 3, Ascoli Piceno 63100, Italy

<sup>d</sup> University of Camerino, School of Science and Technology, Via Gentile da Varano III 26, Camerino 62032, Italy

## ARTICLE INFO

### Keywords:

Earthquake-resistant non-structural components  
Seismic design  
Life-saving furniture  
Destructive furniture tests  
Furniture ultimate load-carrying capacity

## ABSTRACT

This study explores newly developed furniture working as protective elements in the case of seismic events causing damage in buildings. Attention is given to a school classroom where desks and shelving units are the typical furniture adopted. School desks aim to protect against falling ceiling debris, while shelving units are intended to prevent damage to and overturning of partition walls. Previous designs for desks were costly and impractical, whereas shelving units received minimal attention beyond stronger wall connections to partition walls that, however, might be critical during earthquakes, as they can sustain early damage, posing risks even during moderate seismic events. The article outlines the initial structural concepts, preliminary analyses, full-scale prototypes, and experimental tests under extreme conditions. Differently from other proposals that can be found browsing internet, the solutions illustrated and tested in this study use elements of dimensions similar or even smaller to those of traditional school furniture, resulting in weights and costs that are comparable to current industrial productions in the market. The results from this study are expected to provide a novel perspective and design approach for school furniture design in seismic zones, contributing to the broader field of disaster risk reduction and resilience planning in educational environments.

## 1. Introduction

In the past two decades earthquakes in Italy revealed significant vulnerabilities within the country's building stock, especially in buildings with public functions, like schools. The tragic collapse of a school in San Giuliano di Puglia in October 2002, due to a 5.8 magnitude earthquake, resulted in the death of 27 children and teachers [1]. The L'Aquila earthquake in 2009, with a 5.9 magnitude, was particularly devastating, causing 309 fatalities and leaving 1600 people injured. The university residence collapsed, alone resulting in eight casualties [2,3]. The Central Italy earthquakes in August 2016 (magnitude 6.2), October 2016 (magnitude 6.6), and January 2017 (magnitude 5.7) caused 300 fatalities, injuries and severe damage in the constructions, including schools and the heritage buildings of the University of Camerino. These disasters underscored the susceptibility of public buildings to seismic events. Reports, such as the [4,5], noted that many educational facilities at all levels were severely damaged and condemned. Braga et al. [6]

discussed on the extensive non-structural elements' damage in RC buildings, which can vary from small cracks to collapse, pointing the attention on the role those elements played in the overall safety assessment, socio-economic framework, including human casualties and loss of building functionality. Same issues can be caused by other non-structural components such furniture, which overturning or motion can cause serious injuries to people and make the evacuation action even more difficult [7,8]. Materials and analytical methods aiming to describe components' performances were largely investigated [9–11]. However, the shape is crucial in some situations, since it allows to employ furniture as a temporary shelter, thanks to the chance to create a survival triangle. Often, such behaviour is merely coincidental, rather than a result of a deliberate design for life-saving functions.

If attention is focused on school furniture, different proposals for school desks able to resist vertical impacts can be found: the award-winning Earthquake Desk designed by Arthur Brutter and Ido Bruno made of steel and birch plywood able to resist to a 422 kg weight

\* Corresponding author.

E-mail address: [gabriele.tamagnone@umontpellier.fr](mailto:gabriele.tamagnone@umontpellier.fr) (G. Tamagnone).

**Table 1**  
Traditional and life-saving desk geometrical dimensions and shapes.

Specimen	Type	Shape	B [m]	b [m]	h [m]	H [m]	Tabletop area [m <sup>2</sup> ]	Weight [kg]
V series	Traditional	Rectangular	1,1	1,1	0,6	0,75	0,66	15
	Proposed life-saving		1,1	1,1	0,6	0,75	0,66	18
S series	Traditional	Trapezoid	0,88	0,51	0,5	0,75	0,35	14.8
	Proposed life-saving		1,1	0,72	0,5	0,78	0,46	18

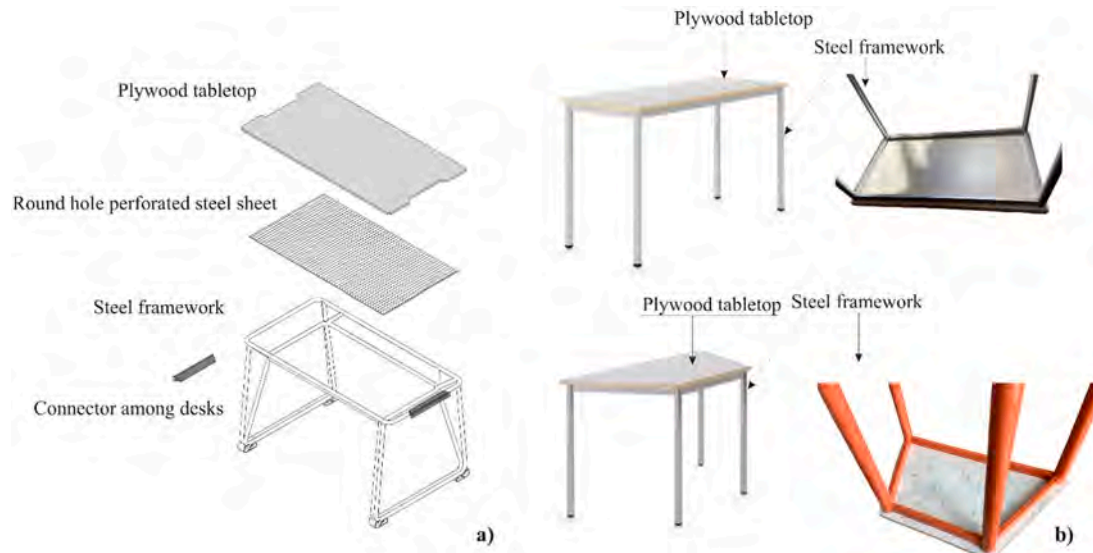

**Fig. 1.** School desk structure: a) Proposed life-saving; b) Traditional (rectangular and trapezoidal versions).

dropped on its tabletop [12], the metal desk developed by an American company (LifeGuard Structures [13]), and Lifeshell [14] entirely made of cross-laminated timber. However, such products are much heavier and more expensive than regular school desks, making unlikely their actual diffusion in schools. In addition, school desks are only one of the elements in the furniture of a classroom. An effective way to protect pupils requires a broader approach, where all furniture elements should be conceived as coordinated products able to provide shelter in the case of damage and failure in the building.

## 2. Objectives and methods

In this work, the possibility to turn non-structural components, specifically school furniture, into lifesaving shields in case of earthquake event is investigated. The idea was to start from traditional school desks and self-supporting shelving units, currently compliant with the intended use standards, modifying them, in design as well as in performance, to enhance products with structural load-bearing features. All the development process phases to obtain ready-to-use commercial products are hereafter exposed and discussed [15,16].

A further novel purpose provided to the state of the art of the technical and scientific literature by the present research is represented by the test protocols. This holistic methodology could be useful to designers and furniture companies interested in the development of earthquake-proof furniture for the school and office sectors as well as to the standard committee which could account for those tests in the next regulatory update.

For both the desk and the self-supporting shelving unit, the process started with the item conceptualisation, to respond to usability and standardised geometry criteria imposed by the norm. This step was then followed by a design phase aimed at incorporating specific features enabling the specimens to provide the sought additional safety and resistance in case of earthquake. Both objects underwent finite elements

analyses which gave a rough estimation of the expected capacity and helped to further refine the concepts. After the prototyping phase, where the partner companies were asked to produce specimens as close as possible to the set geometrical requirements, considering their present manufacturing process, the two proposed furniture solutions were subjected to different testing protocols devised to assess the effectiveness of the new designs. After that, an optimisation phase allowed to fix certain problems encountered during the tests and build better elements, which were then tested in a final experimental campaign.

## 3. School desks

### 3.1. Conceptualization

#### 3.1.1. Traditional school desk

Traditional school desks are conceived to host students and equipment and are produced to meet the dimensional requirements of EN 1729-1 and the safety function of EN 1729-2. Focusing on this work, two traditional desks produced by two different partner companies, one labelled with the letter “V” and the other with the letter “S”, having different shapes and geometrical features, were accounted in the experimental campaign to diversify their performances and compare them with the life-saving ones. Despite the differences (summarized on Table 1), the design and production process of the two desks is essentially the same: they were realized with tube-shaped legs mutually connected via welded joints to the horizontal perimetral frame at the top. The tabletops are made of two of the most widely used materials: (i) particleboards (PB), an agglomerate of wood particles and glue with very low shear resistance, and (ii) veneer boards (VB), which is made of wood ply, normally up to 3 mm thick, overlapped and glued together. Although the latter solution provides better characteristics, these types of boards are meant to perform best for in-plane loads, meaning an out of plane concentrated load could damage severely the top.

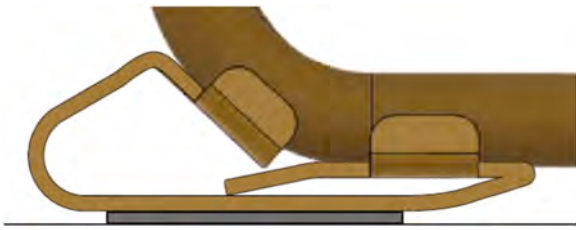

Fig. 2. Proposed dissipative foot.



Fig. 3. Welded elements connecting the inner and outer frames.

### 3.1.2. Life-saving school desk

School desks are simple objects that can be made resistant to falling masses in the case of seismic damage through an oversizing of all its

components, as can be found in many examples. However, the oversizing path produces school desks that are impractical in everyday use, being very heavy to arrange in the different configurations required by a given class, and commonly very expensive, thus, unaffordable by public administrations managing schools. To overcome these limitations, in the study here presented, a different approach was followed: instead of using oversized elements arranged into conventional desk shapes, elements commonly used for traditional school desk constitute an innovative desk shape able to emphasize structural performance. The main novelties of the proposed desk compared to the traditional one (Fig. 1) are: (i) a 1 mm thick steel sheet, fastened to the bottom side of the tabletop; (ii) an external frame (made teal tube-shaped profiles with diameter 22 mm and thickness 1.5 mm) providing direct support to the tabletop and an inner frame with similar geometry connected to the outer frame at the four corners and at the basis, along the shorter sides of the desk.

Specifically, the inner frame provides support to the outer frame, collaborates towards a progressive bending damage in case of strong overloading (being the larger inclination of the legs of the inner frame properly optimized for this task), improves overall stability, and provides a backing protection in case of damage/failure in the upper part. The steel sheet was added to prevent possible brittle failure of the tabletop, typical of non-structural timber panels.

The resulting desk is much lighter if compared to other proposed earthquake-proof desks, more economical, being based on materials, sections, dimensions of elements and manufacturing processes already adopted in common desks, does not have moving components that could harm users, and has a bending-dominated damage in case of significant overloading that exploits the ductility of steel to dissipate impact energy while preserving the volume of the protection area.

The most relevant geometrical features of the tested specimens are summarized on Table 1, including their weight. For sake of comparison, it is worth mentioning the weight of other life-saving desks available in

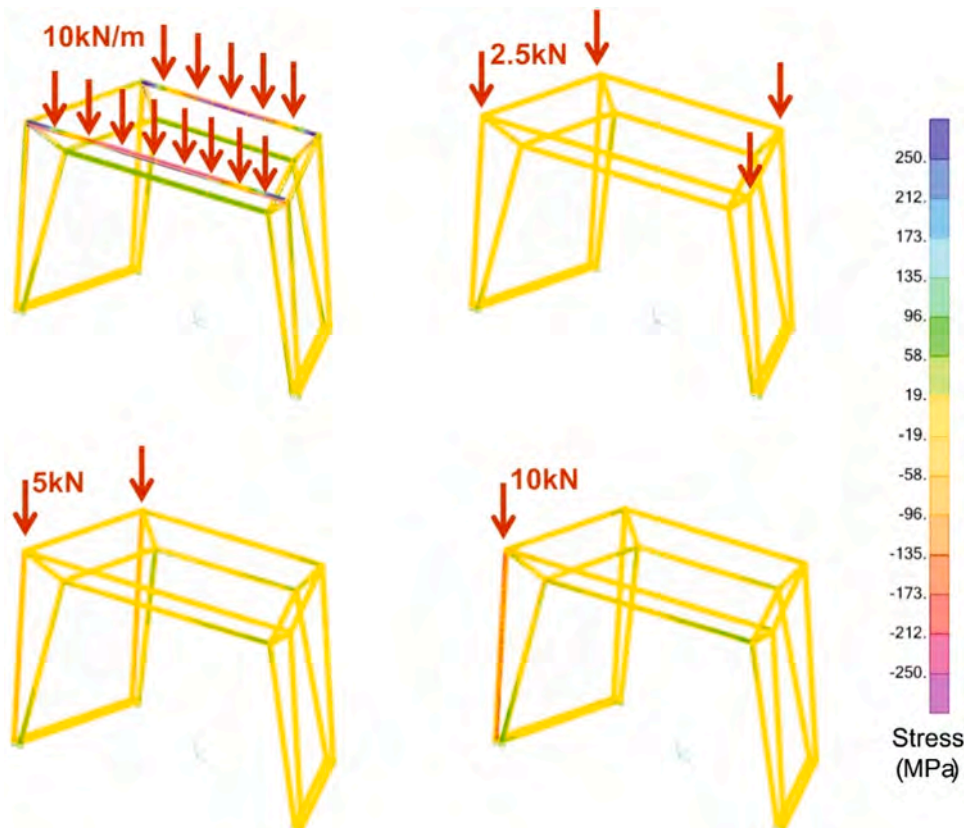

Fig. 4. Examples of preliminary numerical simulations for the design of the proposed life-saving school desk.

**Table 2**  
First experimental campaign: test conditions.

Specimen	Types	Test type	Repetitions	Load type
V series	Proposed life-saving	Static monotonic	1	Distributed
			1	Concentrated without eccentricity
			1	Concentrated with eccentricity $\left(e = \frac{L}{4}\right)$
	Traditional	Static monotonic	1	Concentrated with eccentricity $\left(e = \frac{L}{3}\right)$
			1	Distributed
			1	Concentrated without eccentricity
S series	Traditional	Impact	1	Concentrated without eccentricity
			1	Distributed

**Table 3**  
Second experimental campaign: test conditions.

Specimen	Types	Test type	Repetitions	Load type
V series	Proposed life-saving	Static monotonic	1	Concentrated without eccentricity
			1	Concentrated with eccentricity $\left(e = \frac{L}{6}\right)$
			1	Concentrated with eccentricity $\left(e = \frac{L}{3}\right)$
	Proposed life-saving	Impact	3	Distributed
			1	600 kg
			1	450 kg
			3	300 kg
			1	17.5 kg
	Traditional	Impact	1	450 kg
			1	300 kg
2			36 kg	
1			Concentrated without eccentricity	
S series	Proposed life-saving	Static monotonic	1	Concentrated with eccentricity $\left(e = \frac{L}{6}\right)$
			2	Concentrated with eccentricity $\left(e = \frac{L}{3}\right)$
			2	Distributed
	Proposed life-saving	Impact	1	600 kg
			1	450 kg
			2	300 kg
1	36 kg			

**Table 4**  
Third experimental campaign: test conditions.

Specimen	Types	Test type	Repetitions	Load type
V series	Life-saving optimized	Impact	2	600 kg
	Life-saving + belt		2	
	Traditional		1	
S series	Life-saving optimized	Impact	2	600 kg
	Life-saving optimized + belt		1	
	Life-saving + belt		1	

literature: the Lifeshell desk made of CLT elements has a weight of 119 kg, while the Earthquake Desk designed by Arthur Brutter and Ido Bruno made of steel frame and birch plywood tabletop weights 25 kg (sized to host two students).

After the first experimental campaign, the desks' structure was optimized, in particular: (i) the under table steel sheet was replaced with

a round hole, perforated, version with the same thickness; the aim was to lighten the desks without lose the anti-intrusion function; (ii) four collapsible steel feet, made of 3 mm thick metal sheet, were added to dissipate energy in case of impact (Fig. 2).

Additional optimization operations were carried out after the second impact test campaign, with the welding of additional reinforcement elements (Fig. 3) to connect the inner and the outer frame, to efficiently redistribute the vertical loads and reducing the deflections in bending of the inner frame tube elements.

### 3.2. Preliminary design via numerical simulation

Recent studies investigated the seismic design [17] and modelling [18] of inelastic non-structural elements, providing insights into their strength-reduction factors and response under building floor motions. In this framework, the shape of the school desk was optimized considering vertical distributed and concentrated loads, both symmetric and non-symmetric, through a finite element model implemented in the SAP 2000 software (Fig. 4). The most critical loading condition was identified as a concentrated force at one corner with global stability being the most demanding verification. However, this preliminary numerical study could only provide initial indications, with impact tests needed for deeper insight.

### 3.3. Prototyping and tests

After the preliminary numerical analyses, the proposed life-saving components were pre-dimensioned and prototyped. It is worth highlighting that the two industrial partners, in compliance with the suggested measures, manufactured their products autonomously, based on their equipment, know-how and stocks, so their products could slightly differ from each other's and from the design features for some processing details and dimensions, and which influence will be hereafter explained.

Since the accredited tests for school furniture strength and safety (EN 1729-2:2023 for chairs and tables in educational institutions, EN 16121:2023 for non-domestic storage furniture) consider loads and protocols consistent with their operational functions, in this work, non-standard test methods were proposed and applied to experimentally evaluate the capacity to resist overloading as that expected in the case of damage following seismic events.

The experimental campaign was carried out at the laboratory of the Department of Civil, Construction-Architectural and Environmental Engineering (DICEAA) of the University of L'Aquila. Two different types of tests were carried out on the proposed life-saving school desks: (i) monotonic static tests with both concentrated and distributed load (with and without eccentricity) to test the punching shear capacity of tabletop and the load bearing capacity of the steel frame, respectively; and (ii) dynamic (impact) tests to establish the overall load-bearing behaviour if debris detachment from the ceiling occur.

According to Section 2, two subsequent test campaigns were carried out: during the first, static monotonic and impact tests were performed to compare the performances of life-saving innovative desks with those of traditional ones (as summarized in Tables 2 and 3); then, after optimizing the design, a second impact test campaign was carried out to establish the effectiveness of the supplied enhancements on life-saving desks (Table 4).

#### 3.3.1. Static monotonic tests

To carry out static monotonic tests a suitable setup and equipment was put on stage as shown in Fig. 5. The load was provided by a hydraulic Enerpac RR1010 actuator and was recorded through a 100 kN load cell placed between the actuator and the devices for the load distribution. Those latter consisted of (i) a H-shaped frame for the load redistribution over the longer frame profiles placed under the tabletop (Fig. 5a) and (ii) a 100 mm diameter steel disk laid on the top of the desk

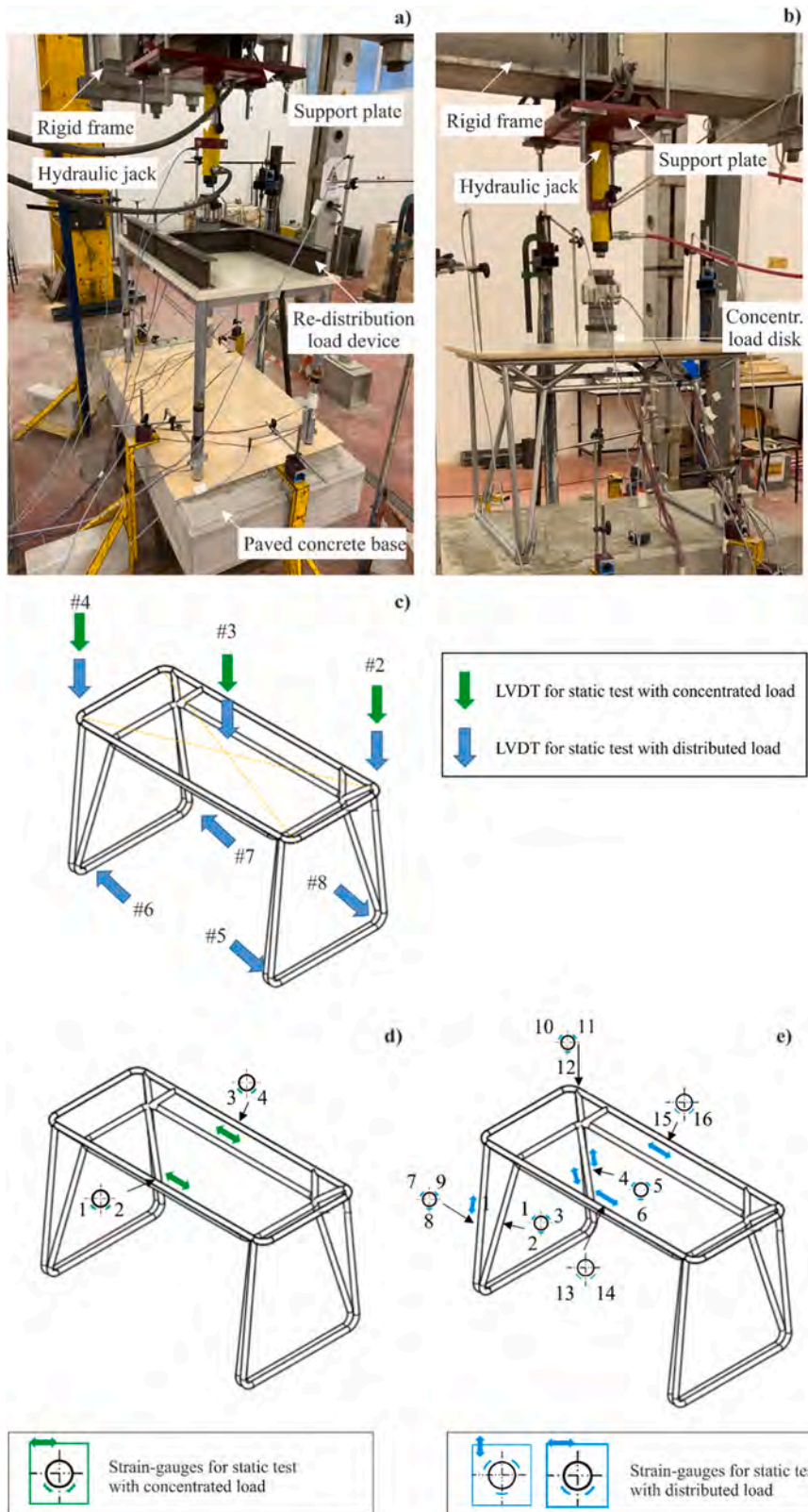

Fig. 5. Monotonic tests on desks: a) Distributed load setup; b) Concentrated load setup; c) LVDT position; d) Strain-gauges position for concentrated load; e) Strain-gauges position for distributed load.

able to produce punching on the tabletop panel (Fig. 5b). The displacements (both of the tabletop and inner/outer frames) were only measured for the innovative desks by using HBM 100 mm inductive displacement transducers (LVDTs). The location of LVDTs is explained in

Fig. 5c. The LVDTs for tests with concentrated load were placed on the diagonal of the top of the desk, one in the centre and two close to the corners, respectively, and the average tabletop's deflection was computed. For the distributed load configuration, additional LVDTs

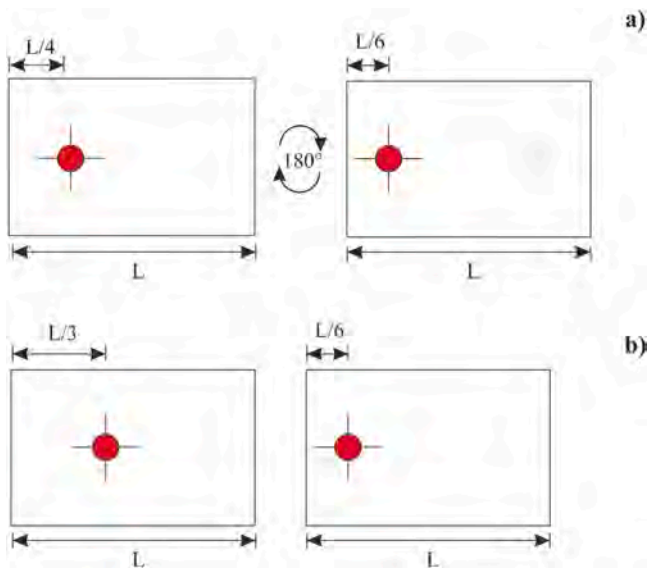

Fig. 6. Scheme of the concentrated load: a) First campaign; b) Second campaign.

were placed on the bottom of the outer frames to measure their possible sliding (Fig. 5c). Traditional desks' displacements weren't monitored due to the expected failure mechanisms (i.e., either concentrated underneath the loading plate and/or brittle).

Additionally, strain gauges (SGs) monitored the strain in the frame of the traditional and life-saving desks. In accordance with (Fig. 5d), when the applied load was concentrated, just 4 SGs were applied to the profiles of the horizontal frames of life-saving desks. In accordance with (Fig. 5a-d), when the applied load was distributed, 16 and 32 SGs were applied to the sub-structure of traditional desks and to the inner and outer frames of life-saving desks, respectively.

Concentrated load tests were all carried out with the load placed in the middle of the tabletop, except for one test where the load was first applied at a distance of one fourth of the longer edge from the shorter one and subsequently at one sixth of the longer edge length from the opposite shorter edge (see Fig. 6a).

In the second campaign, desks were tested as in the first one, however, for the eccentric arrangements, eccentricities were modified and set equal to one third and one sixth of the longer edge from the shorter edge (previously one fourth and one sixth) (see Fig. 6b). The general setup was the same of the previous campaign, and so were the recorded parameters. Tests were carried out in accordance with Table 3, to test the potential of a new set of support (see Fig. 1), not only to overcome the problems highlighted with the failed specimens during the first campaign, but, most importantly, with a view to the following impact tests and how these new supports would help towards dissipation.

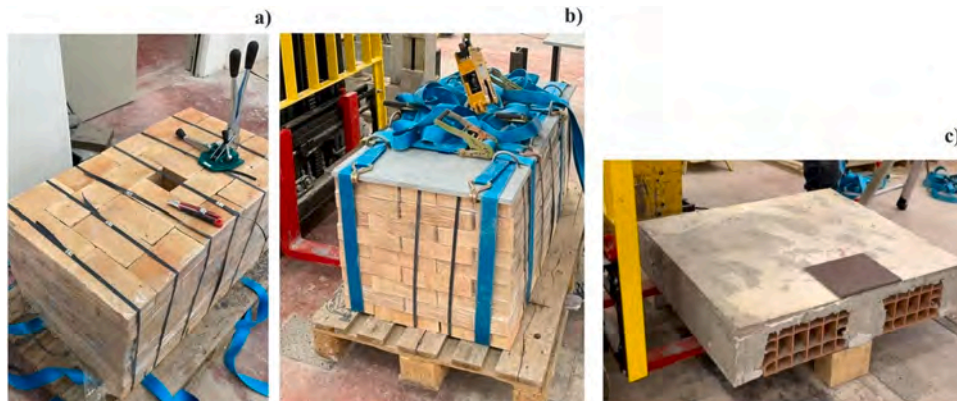

Fig. 7. Impact loads: a) Assembly of brick stack; b) one of the 600 kg brick stack; c) portion of mixed reinforced concrete and hollow tiles floor.

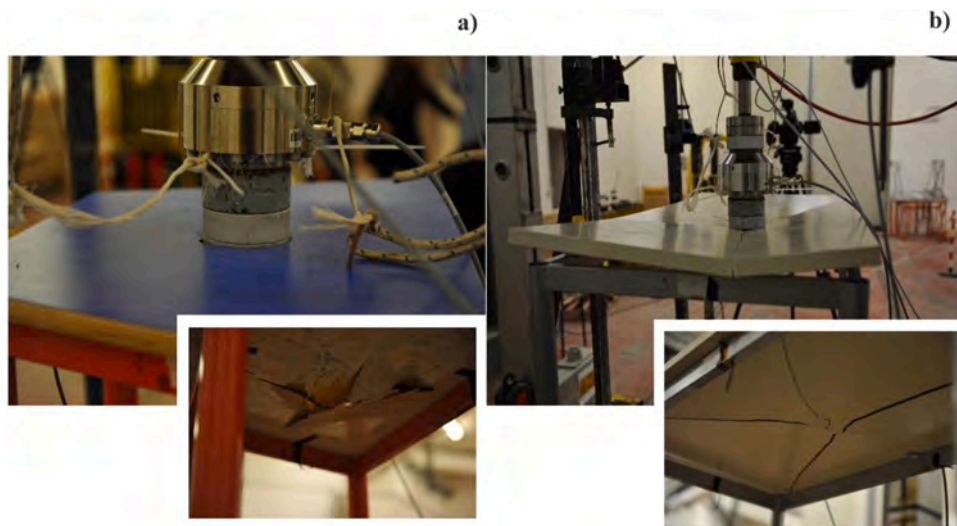

Fig. 8. Traditional desks: a) Collapse of the PB and b) multiply top failure.

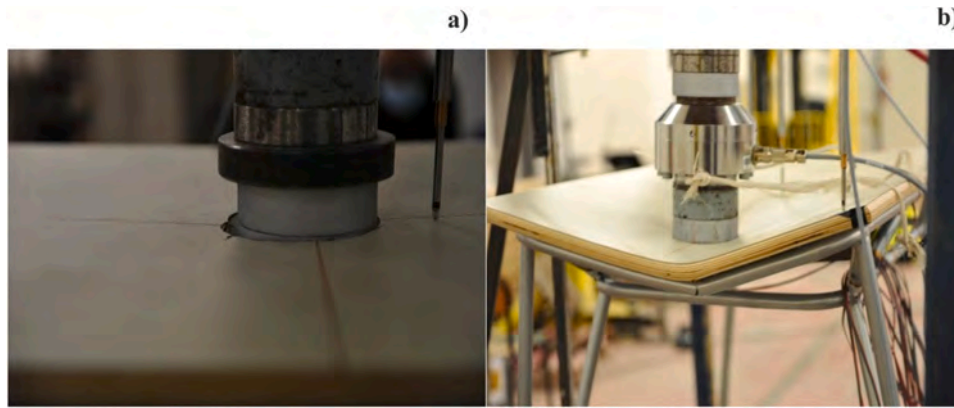

Fig. 9. Collapse of the life-saving desks during the concentrated load test: a) without eccentricity and b) with eccentricity.

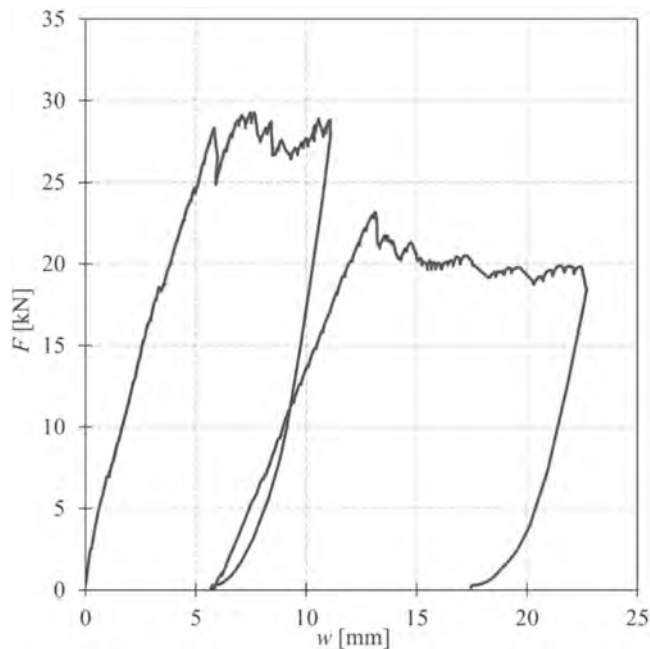

Fig. 10. Force vs Average displacement relationship for the eccentric load tests.

The tests were interrupted, as general rule, when the vertical space underneath the desk became too short, to comply with the safety measures, or the vertical displacement occurred with no increasing load.

### 3.3.2. Dynamic (impact) tests

The target of the proposed life-saving desk prototypes was the safety of its user against falling objects following seismic events. Therefore, impact tests were essential to simulate the effect of a possible upper floor collapse.

Performing full-scale impact tests was challenging due to several reasons: they are uncommon in the field of civil engineering and differ from those made in other engineering fields that mainly test sub-components and small-scale elements. These latter conditions required to establish a novel tests methodology. At first, a suitable height for the load release was chosen; it was 2.5 m high from the desk support surface in consideration of a realistic and common inter-storey height. To ensure an instantaneous load release, a manual, 1-Ton capacity, quick release device was employed. The amount and type of load was deeply analysed to guarantee the same features of real floors in terms of weight and stiffness. Two different scenarios were accounted for the existing floor: (i) a floor built with ancient techniques as brick vaults and domes and

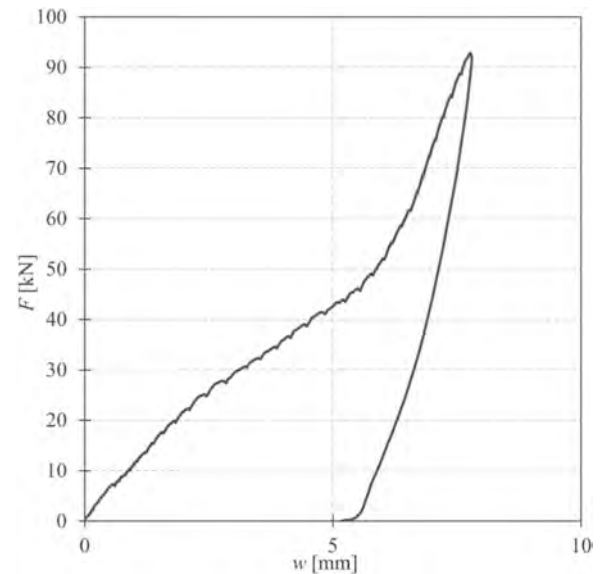

Fig. 11. Force vs Average displacement relationship for a distributed load test on a traditional desk.

(ii) a traditional mixed reinforced concrete and hollow tiles floor.

The typical Italian ancient vaults are characterized by a certain flexibility, due to the thin layer of mortar that keep the bricks together. In some cases, the mortar is degraded or even no longer present, so, in case of collapse, incoherent parts would fall. The idea was to reproduce this possibility by packing brick stacks simply overlapping and wrapping them with clamped bands and plastic film stripes, rather than bonding them (Fig. 7a). A steel plate was settled on the top of the stack to allow its hooking and lifting, further belts were used to improve the holding.

The size, height and load of the stacks were discussed to guarantee the worst impact conditions. The area of the stack was assessed to be equal to the tabletop, while the height varied based on the two mass amounts: 450 kg and 600 kg (Fig. 7b). The effect of a traditional mixed reinforced concrete and hollow tiles floor was simulated by releasing a portion of this floor having as base dimensions 1.0 m x 1.2 m and a height of 0.24 m. The weight of these floor portions was equal to 300 kg. (Fig. 7c).

## 3.4. Results and discussion for desks

### 3.4.1. First test campaign on school desks

3.4.1.1. Concentrated load. For traditional desks, regardless of the usual

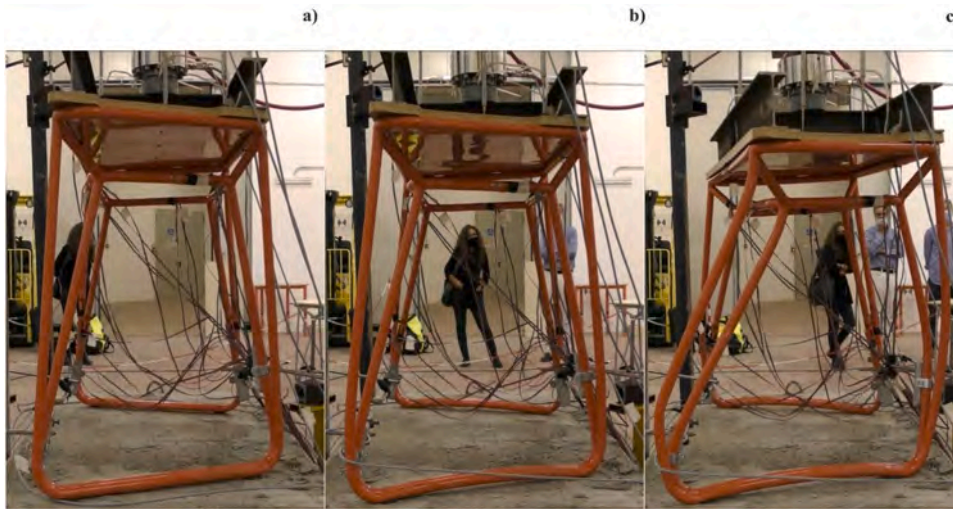

Fig. 12. From left to right, the start of the test, the incipient of buckling, and the final shape of the specimen, respectively.

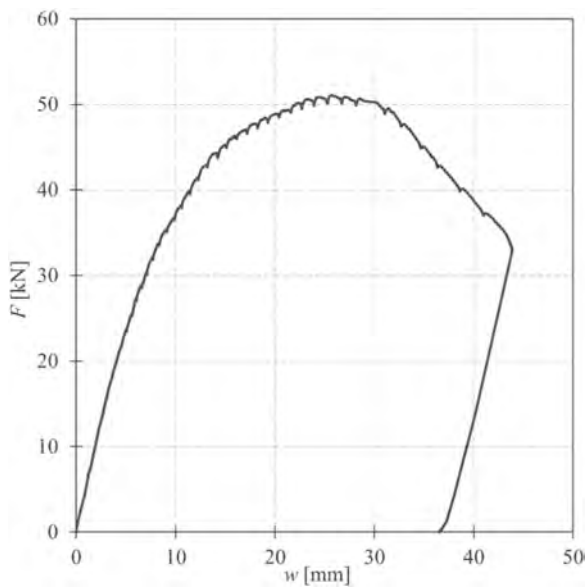

Fig. 13. Force vs Average displacement relationship for the collapsed life-saving desk under distributed load.

higher capacity of the material, the multiply veneer board top fell behind the particleboards top due to the dimensions, and, consequently, supporting conditions, but, most importantly, due to the failure mechanism: the nature of the particleboards allowed it to have a concentrated failure under the loading plate, meaning the capacity were that of the material plus that provided by the friction of the failing area against the still intact surrounding portion. On the other hand, the multiply board couldn't show a concentrated collapse, and the resulting bearable load was massively influenced by its bending capacity (Fig. 8). The particleboards showed a maximum load of 24 kN, whereas the multiply board collapsed after just 7 kN in a very brittle manner.

For life-saving desks, the tests highlighted how the presence of a metal sheet under the wooden tabletop significantly augments strength and ductility when subject to concentrated loads if compared to traditional alternatives

The presence of a metal sheet below the multiply board allowed the top of the innovative solutions to perform in a more ductile manner, thanks to the involvement of the frame in the capacity of the system against this type of load, whereas the traditional alternatives resist just

with the wooden top. The centred load test showed a concentrated failure like that of the PB traditional desk, while the eccentric test presented a fractured, yet ductile, collapse, more similar to the multiply board traditional desk (Fig. 9).

The first test reached a maximum load of 44 kN, while the second recorded a peak of 30 kN in the first phase and 23 kN in the second and a maximum displacement at the centre of the specimen of roughly 50 mm (Fig. 10).

**3.4.1.2. Distributed load tests results.** All the traditional and life-saving desk outperformed the actuator, reaching a peak load of nearly 100 kN. They could have borne a higher load, but the research team agreed it is extremely unlikely, in the scenarios these elements are meant to operate as safety equipment, they would be subject to an accumulated mass greater than 10 t. The one thing all the three tests had in common was that they all showed a first milder slope in their force vs displacement curves, followed by a steeper one (Fig. 11). This was due to the initial collapse of the plastic supports at the base of the legs before the legs could effectively touch the ground and start to be properly loaded. No significant difference in terms of shape and displacement attained was spotted. For this reason, only an example curve is depicted in Fig. 11.

The fourth desk, an innovative one, suffered from a geometrical issue, resulting in an eccentricity of the load in the legs due to the mutual position of the same legs and the plastic supports. Because of the geometry of the new concept, one of the suppliers welded additional supports in line with the legs, resulting in one of the successful tests mentioned above. The other supplier, however, used plastic elements in the horizontal bottom tube connecting the legs. Given these elements were the ones in contact with the ground, and that the load follows the line of the legs, a lever effect took place due to the unalignment of supports and legs. In Fig. 12c, the point when the frame started to buckle can be seen, with the horizontal tube at the bottom of the frame deflected upward due to the mentioned effect, which then caused the legs to bend outward. After this point, the structure started to collapse with no load increase. The unpredictable rotation of the specimen affected the measurements, as few instruments lost contact with the surface they were placed against, but it was still possible to record and plot the force vs average displacement curve, which can be seen in Fig. 13. The maximum load recorded was 51 kN, but it could be argued that this specimen would have behaved the same as the others if supports were the same as the other life-saving desk.

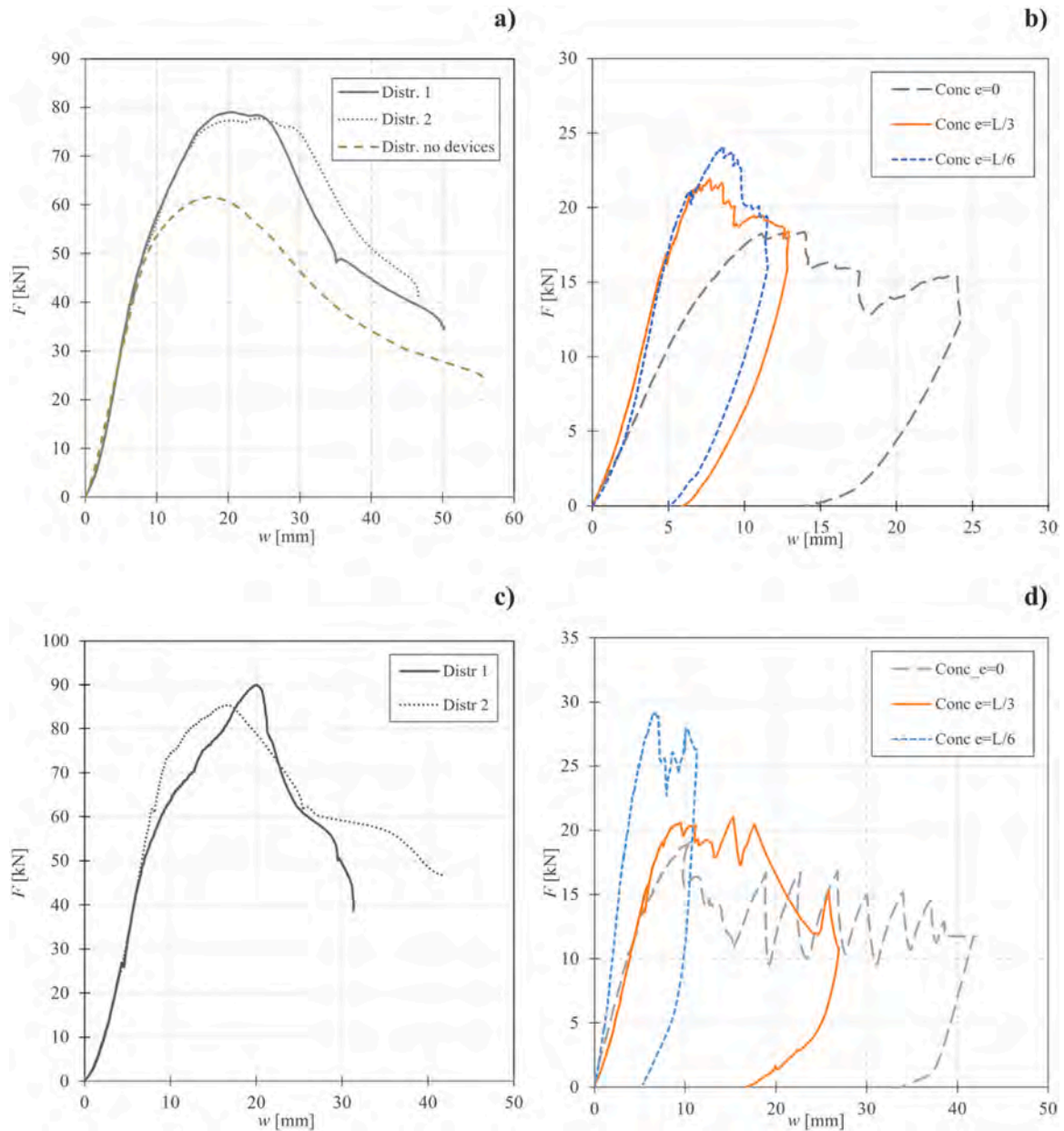

Fig. 14. Force vs Average displacement relationship for distributed load tests – second campaign: a) Distributed loads V-Series, b) Concentrated loads V-Series, c) Distributed loads S-Series, d) Concentrated loads S-series.



Fig. 15. Proposed dissipative foot collapsed after the loading test.

### 3.4.2. Second test campaign on school desks

3.4.2.1. *Concentrated load.* As the load approached the frame, namely, as the point of application moved from the centre to the edge, the specimens showed a higher capacity, yet a lower ductility, as can be seen in Fig. 14b and d. The results for the two series are reported separately for clearness: Fig. 14a and b depict the V-series, whilst Fig. 14c and d the S-series. No difference in the overall behaviour of the desks was observed with respect to the first campaign, as the mode of failure was compatible with those encountered previously.

3.4.2.2. *Distributed load tests results.* The results of the tests are depicted in Fig. 14a-c. The proposed dissipative foot, shown in Fig. 15 at the end of the loading test, even if determining a lower capacity of the system, generated a more ductile response of all the specimens. The mode of failure detected was the same as that of the previously failed specimen, but, in this case, being the supports not perfectly identical, they crashed

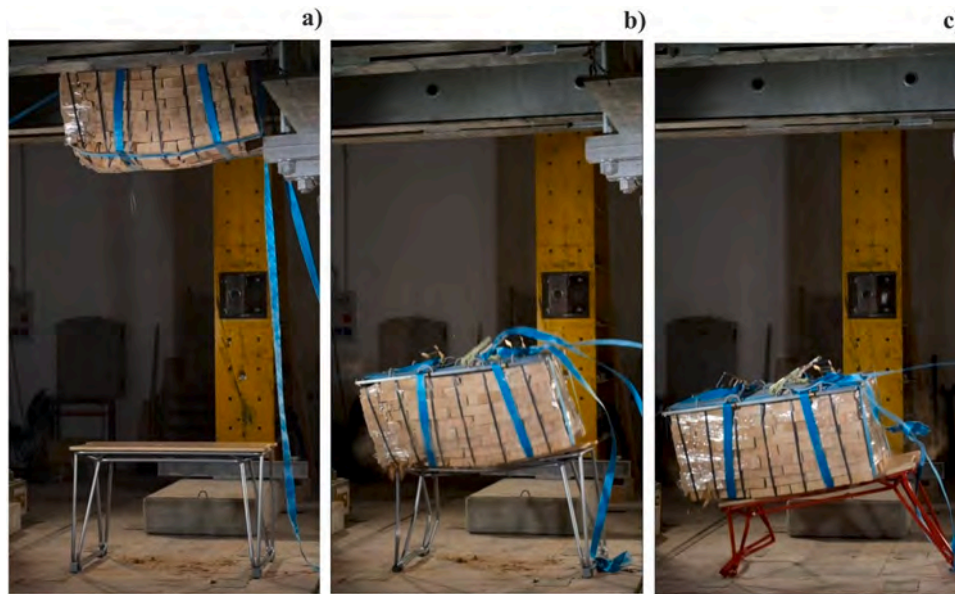

Fig. 16. Impact test performed with a brick stack of 600 kg: a) test setup prior to release; b) impact moment on S prototype; c) impact moment on V prototype.

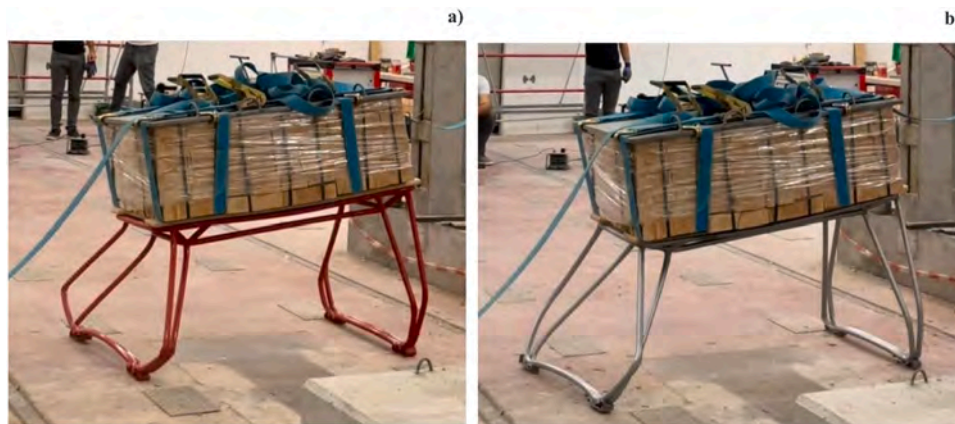

Fig. 17. Impact test performed with a brick stack of 450 kg: a) impact moment on V prototype; b) impact moment on S prototype.

differently, and once the first was flattened, a different distribution of load started in the legs, causing the same, yet more controlled, rotational movement seen in the first campaign.

### 3.4.3. Dynamic (impact) test results

The reliability of desks as a safe shelter in case of earthquake was assessed also via impact tests. The first tests were carried out with brick stacks weighting 600 kg. Both for the V and S prototype, the outer vertical frames bent outwardly in the lower part with a ductile mechanism; in particular, the little mass eccentricity caused a more severe outer vertical frames damage for the V one (Fig. 16).

Tests carried out with brick stacks of 450 kg gave good evidence; although the bending mechanism was still observed, the frames didn't collapse, and the tabletop was intact, ensuring the life-saving function (Fig. 17a-b). Tests highlighted, in both cases, an excessive relative horizontal sliding of outer vertical frames at the floor level. This condition was accounted and fixed in the second version of the prototypes by suitably connecting them to the inner ones.

Other tests were carried out by releasing the 300 kg floor portions. In this case, the most remarkable result for life-saving desks was the bending of the outer vertical frames; neither the horizontal frames nor the tabletop were damaged (Fig. 18). On the other hand, the traditional desk was severely damaged, with one leg crashed and compromised

stability.

Finally, further tests were carried out with reduced loads (17.5 and 36 kg) with the aim to test the tabletops breakout strength in case of collapse of non-structural ceiling elements (i.e., lights, false ceiling portion or projectors). In this case, small cubic packs of bricks were realized and released. As it is evident from Fig. 19, the effect of 36 kg load release on traditional and life-saving desk was the opposite: the traditional tabletop experienced a complete breach of the timber panel and the separation between the top and the steel frame (Fig. 19a-b); the life-saving desk was able to resist by assuring a dissipation of energy through the dissipative feet (Fig. 19c-d).

### 3.4.4. Third test campaign on school desks

The third test campaign was performed after updating the prototypes with suitable reinforcements specifically added to fix the weaknesses highlighted in the previous test campaigns (as described in the previous section). Thereafter, only the most critical tests with the heavier 600 kg weight were repeated. As a result for the optimized specimens of both the series, it was highlighted that the bending of the outer vertical frame was prevented due to the welded additional profiles; nevertheless, the tensile action causing base sliding was still present. To avoid this latter issue, as a quick and effective method, a ratchet belt was tightened between the two side frames (Fig. 20a). As a result, during the impact, no

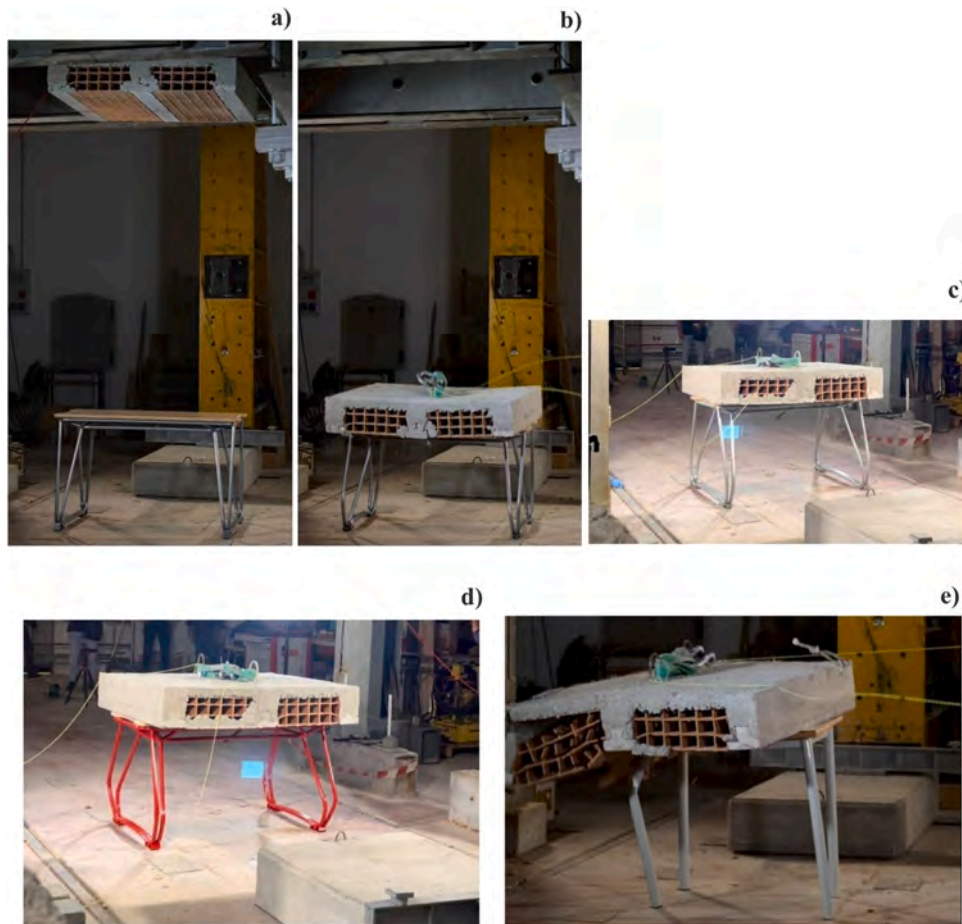

**Fig. 18.** Impact test performed with a floor portion of 300 kg: a) test setup prior to release; b) impact moment on S prototype; c) after the impact moment on S prototype; d) after the impact moment on V prototype; e) after the impact moment on traditional desk.

slip was recorded. This solution was suitably implemented in the final desk prototypes as an additional welded tube-shaped tie-rod.

## 4. Self-supporting shelving unit

### 4.1. Structural conceptualization

Standard shelving units are installed next to a wall and fixed to it through mechanical fasteners. Alternatively, they can be freestanding units adjustable in height and secured to the floor and ceiling. Existing research, including studies [19–23] and international standards such as FEMA E-74 [24], California [25], and Japanese school guidelines [26], primarily focus on securing classic bookshelves to classroom walls for seismic mitigation. However, beyond this basic measure, dedicated research on the seismic performance of these structures is limited. A significant issue with these solutions is that if partition walls don't meet seismic standards, the anchored shelving unit undergoes the same wall's damage or could even be a worsening factor. Similarly, shelving units anchored solely to the floor and ceiling, without additional bracing, are at risk of collapsing during an earthquake due to the potential overturning of adjacent partition walls.

The proposed self-supporting shelving unit (Fig. 21) addresses the limitations of existing designs by serving both as a functional storage solution and a safety device. In normal conditions, it works as a bookshelf hosting interactive whiteboards, teaching materials, and audiovisual equipment (Fig. 21a). However, in the event of an earthquake (Fig. 21b), the unit is designed to protect nearby people by (i) preventing the collapse of the adjacent partition wall and (ii) shielding them from falling debris. More in detail, Fig. 21b compares the behaviour and

deformed shape of the proposed self-supporting shelving unit (left in Fig. 21b) to the one of a traditional sky-to-ground one (right in Fig. 21b) in case of a seismic event. The purple arrows represent the earthquake action, while the orange arrows represent the opposing reactions of the two shelving units. The proposed system is significantly stiffer than the traditional one thanks to the presence of the upper and lower triangular elements that reduce the free span of deflection of the shelving unit. Moreover, the stiffening triangular profiles increase the axial compressive load under horizontal deflection improving the horizontal friction resistance to horizontal loads.

Fig. 22 portrays the structural layout of the proposed self-supporting shelving unit whose uprights are the core elements. Each upright is composed of three elements, a central rectangular hollow profile, sized to work mainly for bending and axial forces, and two symmetric stiffening triangular profiles, subjected to axial force and hosting the central profile. The triangular profiles can be slid over the central one to adjust the height, creating a versatile floor-to-ceiling structure that can fit heights spanning from 2.70 m up to 3.00 m. Once reached the desired height, the triangular profiles are secured to the central profile using self-tapping metal screws. This configuration reduces the free length of deflection of the central profile, empowering simultaneously the performance of top and bottom restraints thanks to the compressive action developed, whilst also simplifying the carriage and installation procedures. The shelving unit will only fail if its connection to the floors is compromised or if the structural capacity of its members is overcome. In addition, a prestress force is applied to the struts to increase the efficiency of the restraints (higher friction resistance) and to maximize the efficacy of a layer of elastomeric material located at the interface between the metal support plates, installed at each end of the uprights, and



Fig. 19. Impact test performed with a floor portion of 36 kg: a) traditional desk tabletop breach; b) traditional desk tabletop-frame separation; c) impact on the life-saving desk; d) with energy dissipation; e) and overall bouncing.



Fig. 20. Impact test performed with a floor portion of 600 kg: a) test setup with ratchet belt; b) the prototype after the impact.

the floors. The elastomeric layers are meant to create a continuous contact surface and to increase the resistance against sliding. Each upright is connected to the successive one thanks to crossbeams, for an overall length of the shelving unit of 3.60 m.

Each of the three modules composing the shelving unit spans 1.20 m and it can accommodate a protective top panel, allowing to achieve the second objective of the life-saving shelving unit, that is providing protection against falling debris for students or people that cannot use school desks as a shelter. To this aim, the length of 1.20 m grants enough space to protect a person in a wheelchair plus an assistant. It is also worth to observe that the proposed system is realized with prefabricated elements, thus, simplifying its production and availability.

#### 4.2. Prototypes

The shelving unit was designed to sustain the overturning action produced by a typical infill partition wall, used within reinforced concrete (RC) frame structures realized between 1960 and 1990, consisting

of a 2 cm thick layer of plaster that covers each of the two faces of 8 cm thick hollow bricks. For the estimation of both the dimension and the maximum acceleration suffered by the infill wall, a real school in the city of Ascoli Piceno, Italy, was taken as case study [27]. With reference to the infills under consideration (length 7.60 m, height 3.0 m), a shelving unit was dimensioned having a total length of 3.60 m and a depth of 0.45 m, encompassing 4 uprights able to span a height between 2.70 m and 3.0 m and 2 crossbeams able to distribute among the uprights the overturning action of the partition wall (Fig. 22). The seismic action, representative of the demand for the dimensioning and check of infills partition towards overturning action and consequently to the shelving unit, was defined according to Italian Building Standards [28]  $F_a = S_a W_a/q_a$  where  $S_a = 1.96$  g is the maximum acceleration experienced by the infill partition during an earthquake having a probability of occurrence of 10 % in 50 years (i.e., a return period of 475 years);  $W_a = 36$  kN is the weight of the non-structural component and  $q_a = 1$  is the behaviour factor. It is useful to specify that the maximum acceleration  $S_a$  was defined in agreement with a simplified expression valid for RC frame

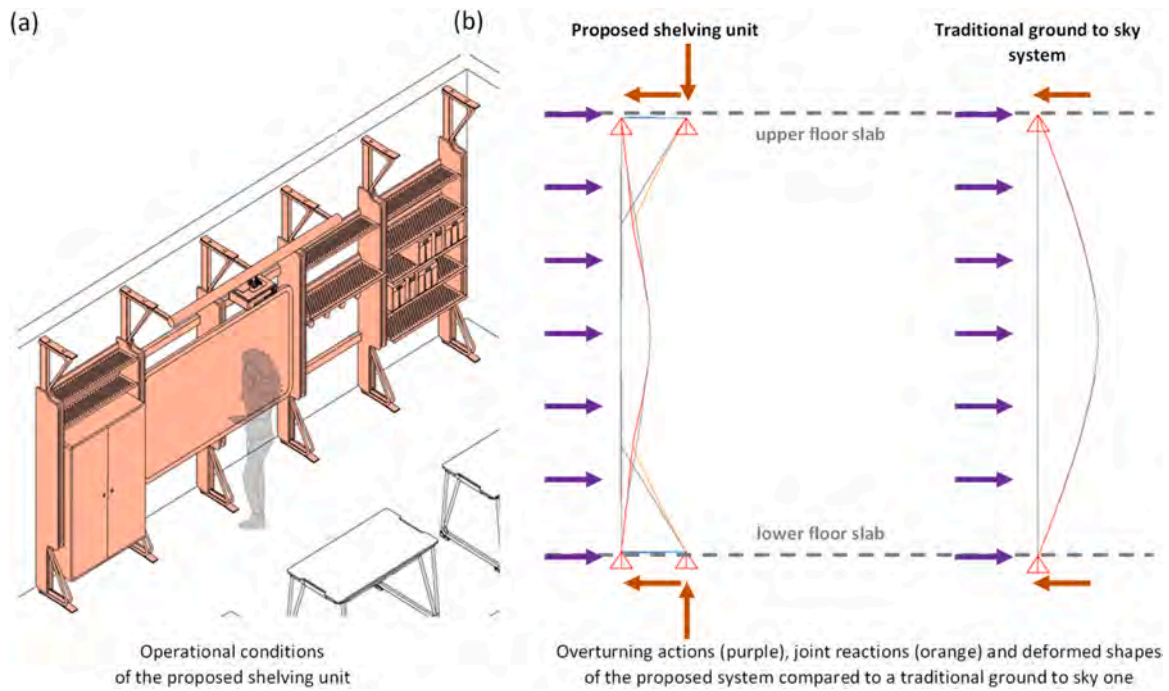

Fig. 21. Working conditions of the proposed shelving unit: a) operational ones; b) in case of earthquake.

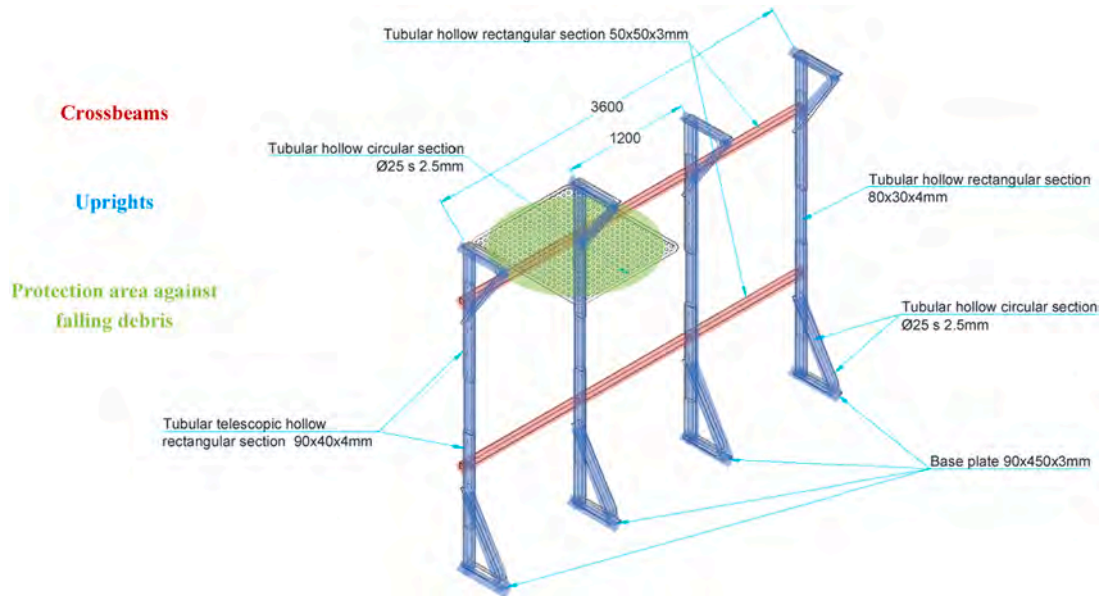

Fig. 22. Layout of the proposed self-supporting shelving unit.

buildings, as suggested by the instructions for the applications of Italian Building Standards [28], while the  $q_a$  was assumed equal to one, instead of two as suggested for infills and partition walls, for safety reasons and to free the design action from a specific infill partition. Accordingly, the seismic design action to be considered for the proposed self-supporting shelving unit results in  $F_a = 71.5$  kN, i.e., each of the two internal uprights are designed to carry  $1/3$  (23.8 kN) of such force according to their influence areas.

Two Finite Element Models (FEMs) for a single stud related to the maximum height of 3.0 m, loaded with one third of the design action  $F_a$  distributed over the stud's height, were implemented in the SAP2000 software. The models differ for the number of connection points between the central tubular profile and the two telescopic stiffening

profiles. Fig. 23 shows the one that provided the highest stresses that were used for the dimensioning of the cross sections of the elements composing a single stud. Once known the stresses on the structural elements, their dimensions were defined as follows: central profile  $80 \times 30 \times 4$  mm, telescopic tubular profiles  $90 \times 40 \times 4$  mm, circular stiffening profiles with diameter 25 mm and thickness 2.5 mm, base and top plates  $90 \times 450 \times 3$  mm.

#### 4.3. Prototyping and tests

The experimental campaign was carried out at the laboratory of the Department of Civil, Construction-Architectural and Environmental Engineering (DICEAA) of the University of L'Aquila. The self-supporting

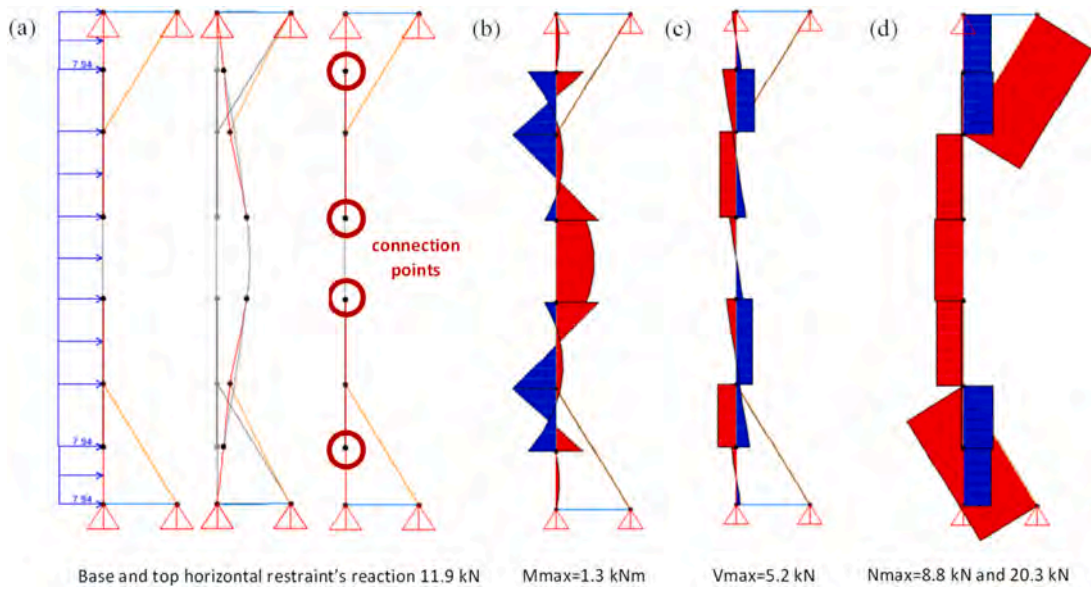

Fig. 23. FEM model of the single telescopic upright: a) applied load, deformed shape and number of connection points among profiles; b) bending action; c) shear action; d) axial action.

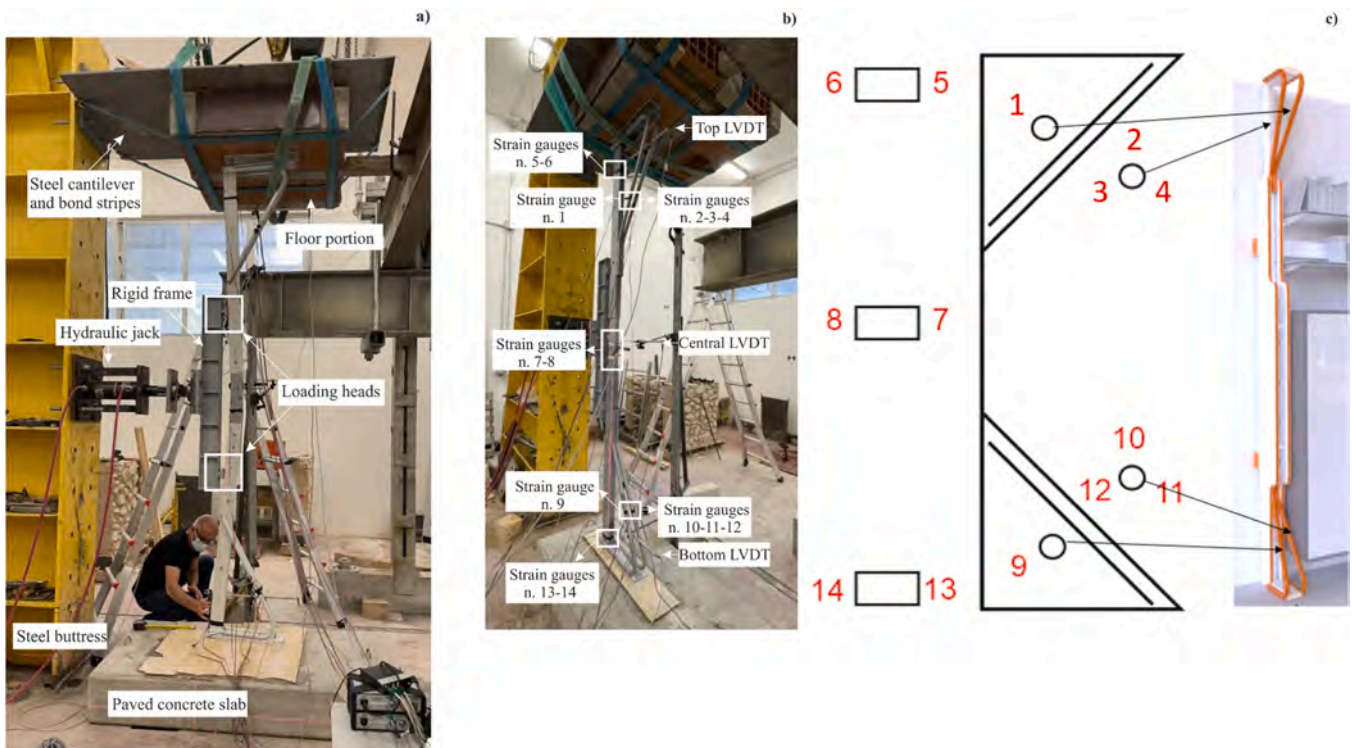

Fig. 24. Static test performed on the LBDPs prototype: a) test setup; b) test instruments; c) strain gauge position.

shelving units were tested to achieve their maximum horizontal load-bearing features by performing static cyclic tests with real boundary constrains conditions.

The test methods were specifically designed for the tested elements. However, given the significance of research on non-structural components during seismic events, a technical guideline was recently proposed, providing standardized testing protocols, facilitating easy replication by researchers and companies, such as for qualification purposes [29].

#### 4.3.1. Tests methods

The two industrial partners involved in the project of the life-saving furniture system realized four uprights each; neither of them used the cross-sections of the structural members designed because of availability. The result are two versions of the shelving unit, one with heavier profiles and one with lighter profiles, which represent a sort of Upper Bound Design Properties (UBDPs) and Lower Bound Design Properties (LBDPs). However, in both cases the triangular profiles were realized with circular hollow sections characterized by slightly lower thicknesses. Therefore, the tests performed on these prototypes provided the opportunity to evaluate the influence of the different stiffness on the

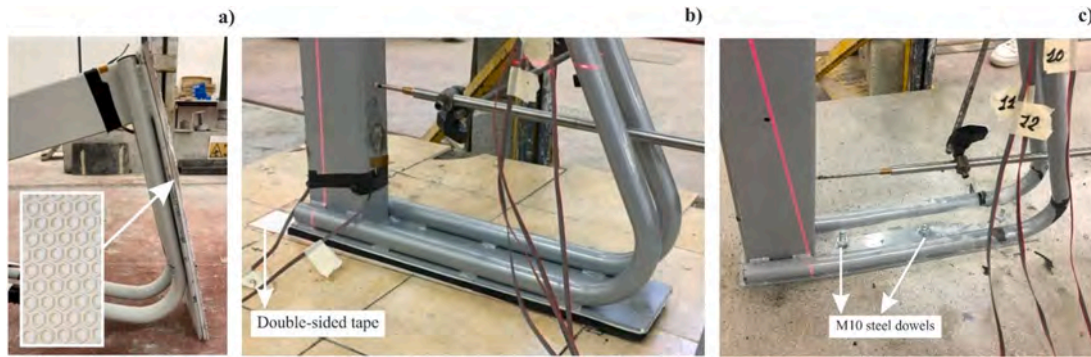

Fig. 25. Base restraint: a) Elastomeric layer; b) Elastomeric layer + double-sided tape; c) M10 steel dowels.

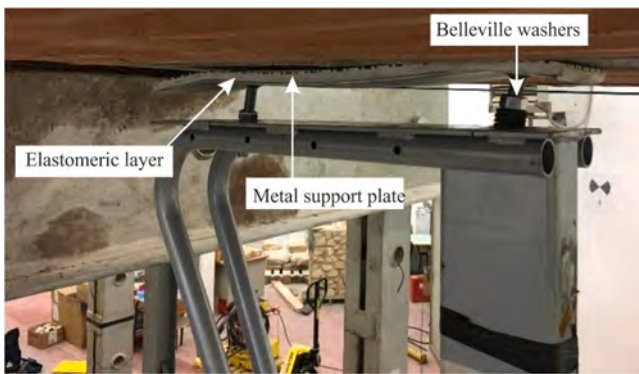

Fig. 26. Metal support plate and Belleville washers.

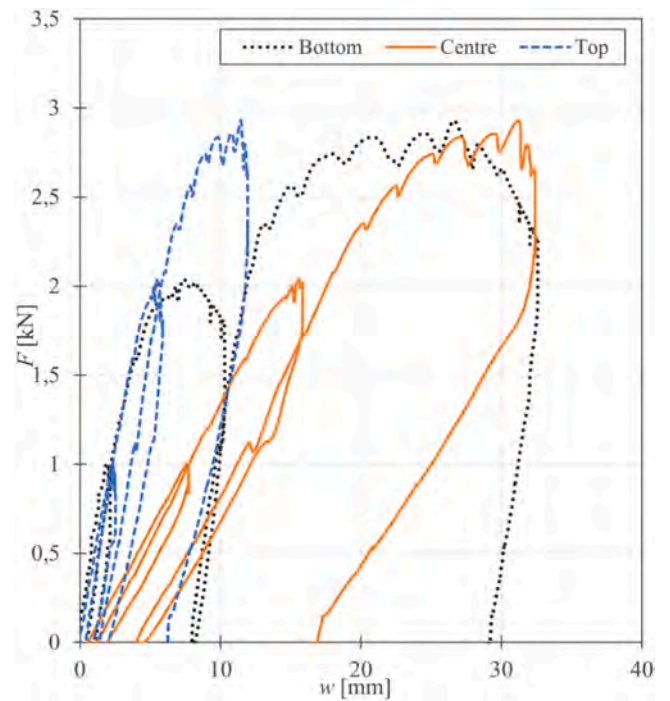

Fig. 28. Force-displacement plot that highlights the base sliding.

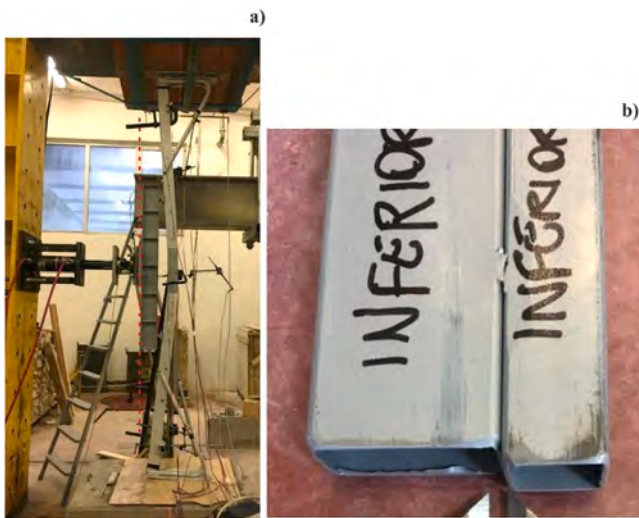

Fig. 27. First test evidences: a) Arched deformation shape; b) Detail of weld joint collapse.

activation of the inclined leg static scheme expected, on the ultimate capacity of the members and on the efficiency of the different restraints tested. These latter spans from double-sided adhesive tape to mechanical fasteners for concrete surfaces.

The cyclic experimental tests performed aims to shed light on: (i) the efficiency of the different solutions for the base restraints in contrasting the sliding; (ii) the efficiency of the top restraint with different values of prestress force, when the upright is installed below a concrete joist of the floor or below the hollow tiles element of the traditional floor; (iii) the effective activation of the inclined leg mechanism and the

characterisation of the element belonging to the telescopic studs that leads to the failure of the system.

The test setup (Fig. 24a) and boundary conditions were arranged to suitably reproduce the worst real working conditions of the self-supporting shelving unit in case of seismic events; this consists of the pushing effect of a typical infill partition on the telescopic uprights, which may cause its overturning. The stud was symmetrically loaded at two points 1/3 of the total length apart (Fig. 24b-c). The load was applied by a double effect, 300 kN hydraulic jack which spreads the load via a rigid frame fixed sideways the piston on the loading heads. The whole system was secured to a steel buttress by a bolted connection.

The upper and lower setup boundary elements were realistically reproduced by manufacturing, respectively, a reinforced concrete paved slab and some traditional reinforced concrete joist and hollow tiles mixed floor portions. This latter was secured to a steel cantilever through high resistance bond stripes; moreover, additional support was given by the overhead crane vertical pulling action. This arrangement was settled to avoid undesired vertical compressive load on the upright. Instruments, such as LVDTs and SGs, were placed on the self-supporting shelving unit components (Fig. 24) to measure the horizontal displacements as well the strains evolution in some specific points. The loading

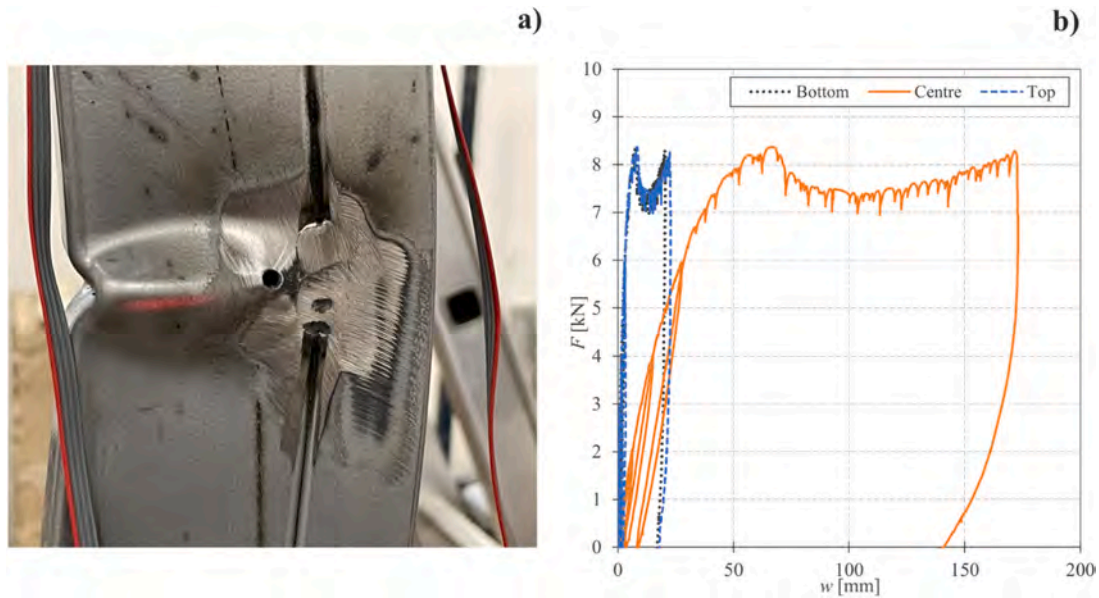

Fig. 29. Strength test with dowels: a) Local buckling of upright profiles; b) Force-displacement plot that highlight the restraint activation.

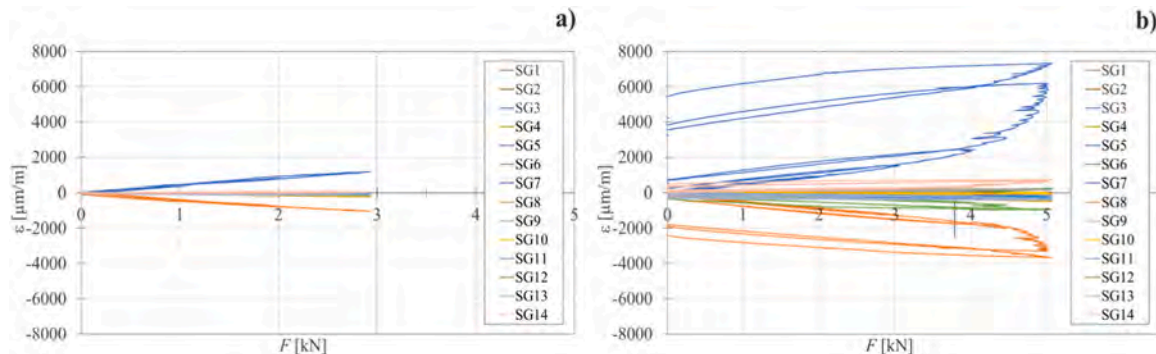

Fig. 30. Strain-gauges results: a) Test three with base sliding; b) Test five with upright plasticization.

cell was suitably placed between the jack and the rigid beam that distribute the load.

Both versions of the shelving unit were tested under different boundary configurations with the aim of gradually increasing the system's bearing capacity. A layer of elastomeric material accomplished the base contact between the concrete slab and the metal plate (Fig. 25a). Setting this as reference configuration, the base contact was successively increased by adding (i) three stripes of double-sided tape (Fig. 25b) and (ii) steel dowels (Fig. 25c).

A layer of elastomeric material realized the contact between the ceiling floor and the metal support plates. Additionally, Belleville washers were provided to apply a vertical prestress force (Fig. 26). Finally, the stud's strength was tested by removing the metal support plate and employing only steel dowels to join both the base with the concrete slab and the ceiling floor with the upper plate.

#### 4.4. Results and discussion

The prototype describing the LBDPs of the telescopic uprights was first tested under the reference configuration conditions with the upper metal support plate placed under the concrete joist of the ceiling floor and 4 kN prestress force applied by the Belleville washers clamping. The resulted restraints activation was evident from the consequent upright arched deformation shape (Fig. 27a). The test ended when the welding joints between the two upright profiles started to collapse (Fig. 27b).

The recorded force was 6.5 kN.

The following two tests were carried out by putting the upper metal support plate under the hollow tiles of the ceiling floor. The washers' prestress force was, as a precaution, reduced to 2 kN in the first test and then brought back to 4 kN in the second one. In both cases, the activation of base sliding mechanisms caused test interruption at an applied force level of 3 kN (Fig. 28).

The fourth test was carried out by putting two additional M10 dowels as base connection to prevent the plate sliding; the washers' prestress force was 2 kN. By adopting this solution, the base plate was suitably fixed, therefore, the upright arched deformation shape was observed. Despite the prestress level being kept low, the test ended due to the hollow tile breach. The recorded applied force was equal to 5 kN. The last test was done to investigate the upright strength; therefore, the upper and lower plates were fixed to the concrete joist and to the base plate, respectively, by three M10 dowels each. The expected stud arched deformation was observed and a higher maximum horizontal force equal to 8.5 kN was recorded. The most relevant damage involved the inclined hollow circular profiles and the local buckling of the upright hollow box profile (Fig. 29).

In Fig. 30, the comparison of strain-force in test three, where the base sliding occurred, and test five, where the presence of dowels avoided this phenomenon, is provided. The mechanical fasteners allowed the arch deformation with evident upright plasticization in the centre line points, as recorded by SG 7 and 8.

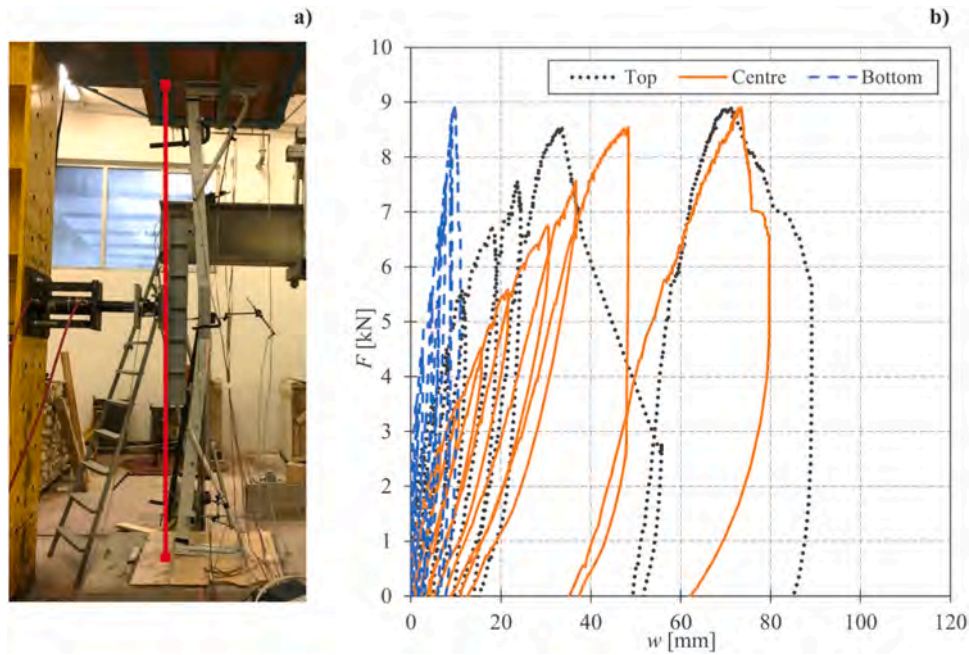

Fig. 31. Test#5 results: a) Cantilever shape deformation; b) Force-displacement plot.

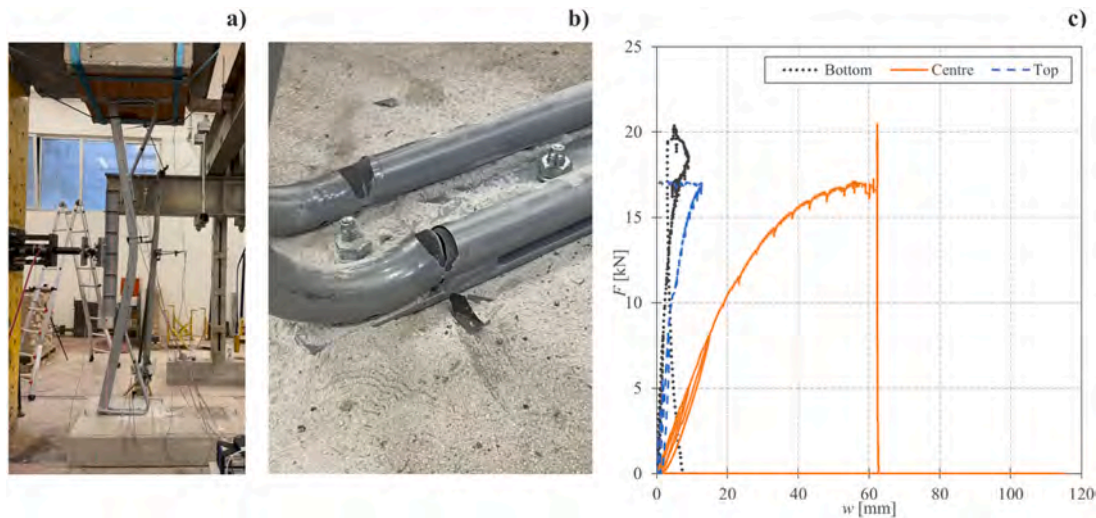

Fig. 32. Test#6 results: a) Arched shape deformation; b) Tube-shaped profiles collapse; c) Force-displacement plot.

The prototype describing the UBDPs of the telescopic uprights was tested too. As before, the first two tests were carried on under the reference configuration, with the upper metal support plate placed under the concrete joist of the ceiling floor and prestress forces of 4 kN and 8 kN, respectively. The same results were achieved, consisting in a base sliding for a horizontal load level of 3.0 kN. The washers' prestress force was maintained equal to 8 kN also in the next two tests. The third test was performed by adding three double-sided tape strips at the base, so to increase the bonding and to avoid the sliding. Beside the maximum force level doubled in the latter tests, sliding mechanism kept on developing. For the fourth test, the base connection was realized by adding two M10 dowels. As highlighted for the LBDPs, the use of steel connectors generated a fixed restraint at the base, therefore, the upright arched deformation shape was observed. After the application of a horizontal force of 8.5 kN, the upper metal support plate slid, and the test stopped (Fig. 31). The static scheme changed from simply supported beam to cantilever due to the weakening of the upper restraint.

The fifth test was carried out by placing the upper metal support plate under the hollow tiles of the ceiling floor and lowering the prestress force to 2 kN. The load bearing capacity was the same recorded in test #4 and sliding mechanism was still observed. As for the LBDP prototype, the last test was performed to investigate the stud's strength. To compare the results, the same number, type and connector's position of the LBDP last test were reproduced. The result was the expected upright arched deformation shape and the highest maximum horizontal force equal to 21 kN was recorded. Hard damage in the inclined hollow tube-shaped profiles were observed (Fig. 32).

The main results from tests on self-supporting shelving units are summarized in Table 5. The capacity-to-demand ratio (C/D) was evaluated by assuming a demand force equal to the design force (23.8 kN, as previously defined), while the capacity was assumed as the experimental maximum recorded force. Restraints realized with elastomeric layer or elastomeric layer plus double-sided tape strips were not able to perform as expected, resulting in a reaction force sometimes lower than the

**Table 5**  
Summary of main results for self-supporting shelving units.

Conditions	Test#	Position of the upper metal support plate	Base restraint type	Prestress force [kN]	Maximum force [kN]	Failure Mechanism	C/D [-]
LBDPs	1	Concrete joist	Elastomeric layer	4	6.5	Damage on profile's welded joints	0.3
	2	Hollow tiles	Elastomeric layer	2	2	Base sliding	0.1
	3	Hollow tiles	Elastomeric layer	4	2.9	Base sliding	0.1
	4	Hollow tiles	Elastomeric layer + 2M10 dowels	2	5	Base sliding	0.2
	5	Concrete joist + 3M10 dowels	3M10 dowels	0	8.5	Profile's arched deformation with local buckling	0.4
UBDPs	1	Concrete joist	Elastomeric layer	4	3	Base sliding	0.1
	2	Concrete joist	Elastomeric layer	8	3	Base sliding	0.1
	3	Concrete joist	Elastomeric layer + double-sided tape strips	8	6	Base sliding	0.3
	4	Concrete joist	Elastomeric layer + 2M10 dowels	8	8.5	Top sliding	0.4
	5	Hollow tiles	2M10 dowels	2	8.5	Top sliding	0.4
	6	Concrete joist + 3M10 dowels	3M10 dowels	0	21	Profile's arched deformation with damage on the hollow tube-shaped profiles	0.9

prestress force (i.e., friction coefficient lower than the expected value for a rubber compound). Moreover, the designed arch mechanism never developed as expected in the FEM model of Fig. 23 due to the curved shape of the stiffening triangular profiles. The circular hollow profiles composing such element of the upright behave not as pure truss beams, showing lower stiffness and anticipated failure in bending (see Fig. 32). Consequently, only in test #6 of the prototype UBDPs has drawn near the design load, highlighting the critical relevance of the boundary conditions and the negative influence of the curved stiffening triangular element, used by the producers to simplify the construction process. Nevertheless, the potentialities of the proposed solution were evident and C/D ratios larger than 1 are expected if care is given to the vulnerabilities shown by the experimental campaign.

## 5. Conclusions

This paper describes a new life-saving furniture systems consisting of school desks and self-supporting shelving units thought for school buildings that are not able to ensure seismic safety to students and teachers. A wide experimental campaign was conducted with the aim of verifying the efficiency of the proposed furniture and to characterize their ultimate capacities towards different load and restraints conditions.

For the quasi-static test campaigns on desks, the new concepts showed promising characteristics, namely, higher ductility and resilience in repeated tests. The dynamic test campaign gave appreciable experimental evidences: *i*) the tabletops were never damaged during the impact, regardless of the amount and type of load; *ii*) the horizontal and inner vertical steel frames only deflect without collapsing; *iii*) the outer vertical frames were severely damaged only if the 600 kg load was not centred otherwise they bent outwardly in the lower part with a ductile mechanism and slid relatively at the base level. Some trial and error were necessary to iron out prototyping imperfections evidenced by unexpected behaviours, leading to an optimised version of the proposed desk.

For the self-supporting shelving unit, boundary conditions proved to be highly influential for both capacity and deformation. The expected arch behaviour was partially achieved only when perfect bond between horizontal plates and horizontal supporting surfaces, namely, floor and ceiling, was performed, increasing the maximum reached load from 3 kN to 21 kN. The avoidance of sliding between plates and supports will be key for the reliability and future commercialisation of this item. Once the sliding of top and bottom restraints is avoided and the pure truss behaviour of the stiffening triangular profiles granted, the design performance can be achieved. Nevertheless, the tests suggested that the direction of work is promising, yet further detailing and prototyping is

needed.

The two prototypes showed improved capacity and additional features if compared with currently on the market counterparts, using already in-house materials and manufacturing processes, rendering them readily producible at scale with minimal cost increase and additional precautions, especially when the self-supporting shelf unit is considered.

## CRediT authorship contribution statement

**Sciomenta Martina:** Formal analysis, Investigation, Resources, Data curation, Writing – original draft, Writing – review & editing, Visualization. **Tamagnone Gabriele:** Formal analysis, Investigation, Resources, Data curation, Writing – original draft, Writing – review & editing, Visualization. **Gioiella Laura:** Conceptualization, Methodology, Formal analysis, Investigation, Writing – original draft, Writing – review & editing, Visualization. **Micozzi Fabio:** Conceptualization, Methodology, Formal analysis, Investigation, Writing – original draft, Writing – review & editing, Visualization. **Zona Alessandro:** Conceptualization, Methodology, Formal analysis, Investigation, Writing – original draft, Writing – review & editing, Visualization, Supervision. **Dall'Asta Andrea:** Conceptualization, Supervision, Funding acquisition. **Fragiacomo Massimo:** Investigation, Resources, Supervision, Funding acquisition.

## Declaration of Competing Interest

To the editors of the special issue *Nonstructural Elements in Buildings and Seismic Resilience* in the journal *Engineering Structures*

For the submission entitled “Experimental testing of school furniture designed with life-saving functions in case of earthquakes”, the authors Martina Sciomenta, Gabriele Tamagnone, Laura Gioiella, Fabio Micozzi, Alessandro Zona, Andrea Dall'Asta, Massimo Fragiaco declare no competing interests.

## Acknowledgments

This research was carried out within the activities of the project “LIFE-SAVING Sustainable Design of Anti-Seismic Furniture as Smart Life-Saving Systems during an Earthquake” funded by the Italian Ministry of University and Research within the framework PON 2015–2018 in the Specialization Area of “Design, Creativity and Made in Italy”, coordinated by the University of Camerino. The Authors are grateful to the Principal Investigator Lucia Pietroni and the industrial design research team at the University of Camerino (Jacopo Mascitti, Alesandro Di Stefano, Daniele Galloppo, and Davide Paciotti). The Authors

acknowledge the constructive interactions with the industrial partners Camillo Sirianni s.a.s. (Soveria Mannelli, Italy) and Vastarredo s.r.l. (Vasto, Italy) in the design stage and in developing the tested prototypes. The Authors are also grateful to the technicians of the Laboratory of the University of L'Aquila, Edoardo Ciuffetelli and Alfredo Peditto, for their valuable support during the tests. In addition, the Authors of the University of Camerino acknowledge support in the subsequent developments of the research from the European Union - NextGenerationEU, Mission 4, Component 2, under the Italian Ministry of University and Research (MUR) National Innovation Ecosystem grant ECS00000041 - VITALITY - CUPJ13C22000430001 - Project number ARS01\_00914.

### Data availability

Data will be shared with those interested once all the patent applications come to a final result, either positive or negative

### References

- [1] Istituto Nazionale di Geofisica e Vulcanologia, Earthquake with magnitude of ML-MEDNET 5.4 on date 31-10-2002 and time 11:33:00 (Italy) in region 1 km SW Bonefro (CB), (2002). ([http://terremoti.ingv.it/en/finitesource\\_summary/36092321](http://terremoti.ingv.it/en/finitesource_summary/36092321)) (accessed 23 October 2024).
- [2] Istituto Nazionale di Geofisica e Vulcanologia, Earthquake with magnitude of Mw 6.1 on date 06-04-2009 and time 03:32:40 (Italy) in region 2 km SW L'Aquila (AQ), 2009. (2023). ([http://terremoti.ingv.it/en/finitesource\\_summary/36092321](http://terremoti.ingv.it/en/finitesource_summary/36092321)) (accessed 20 October 2024).
- [3] M.G. Di Francesco, R., Tiberii, La notte dell'Aquila [The Aquila night], Palermo, 2010.
- [4] W. Salvatore, S. Caprilli, V. Barberi, Rapporto dei Danni Provocati dall'Evento Sismico del 6 Aprile sugli Edifici Scolastici del Centro Storico dell'Aquila, 2009. ([http://www.reluis.it/doc/pdf/Aquila/Rapporto\\_danni\\_scuole\\_Aquila.pdf](http://www.reluis.it/doc/pdf/Aquila/Rapporto_danni_scuole_Aquila.pdf)).
- [5] Perrone D, Calvi PM, Nascimbene R, Fischer EC, Magliulo G. Seismic performance of non-structural elements during the 2016 Central Italy earthquake. *Bull Earthq Eng* 2019;17:5655–77. <https://doi.org/10.1007/s10518-018-0361-5>.
- [6] Braga F, Manfredi V, Masi A, Salvatori A, Vona M. Performance of non-structural elements in RC buildings during the L'Aquila, 2009 earthquake. *Bull Earthq Eng* 2011;9:307–24. <https://doi.org/10.1007/s10518-010-9205-7>.
- [7] Masatsuki T, Midorikawa S. Simulation of seismic behavior of furniture in high-rise residential buildings due to long-period ground motion. *J Jaee* 2015;15:6\_1–6\_11. [https://doi.org/10.5610/jaee.15.6\\_1](https://doi.org/10.5610/jaee.15.6_1).
- [8] Meguro K, Ito D, Sato Y. Efficiency Of furniture overturning protection devices during earthquakes- a experimental and numerical study. *14th World Conf Earthq Eng* 2008.
- [9] Migliaccio G. Analytical evaluation of stresses and strains in inhomogeneous non-prismatic beams undergoing large deflections. *Acta Mech* 2022;233:2815–27. <https://doi.org/10.1007/s00707-022-03247-x>.
- [10] Migliaccio G. Analytical prediction of the cross-sectional shear flow in non-prismatic inhomogeneous beamlike solids. *Thin-Walled Struct* 2023;183:110384. <https://doi.org/10.1016/j.tws.2022.110384>.
- [11] Desroches, R., Migliaccio, G. and Royer-Carfagni, G. Structures That Can Be Made with Carbon Nanotube Fibers but Not with Other Materials, *Journal of Engineering Mechanics* Volume 148, Issue 12 [https://doi.org/10.1061/\(ASCE\)EM.1943-7889.00002138](https://doi.org/10.1061/(ASCE)EM.1943-7889.00002138).
- [12] G. International, Made in Bhutan The Earthquake Desk, (n.d.). (<https://www.geohaz.org/all-projects/producing-affordable-earthquake-desks>).
- [13] R. von Bereghy, LifeGuard Structures, (n.d.). ([www.lifeguardstructures.com](http://www.lifeguardstructures.com)).
- [14] Fellin M, Polidori M, Ceccotti A. Cross laminated timber furniture providing shelter during earthquakes. Lifeshell public domain release. *Interdiscip Perspect Built Environ* 2022;2. <https://doi.org/10.37947/ipbe.2022.vol2.2>.
- [15] Pietroni L, Mascitti J, Galloppo D. Life-saving furniture during an earthquake. Intelligent, interconnected and interacting. *AGATHÓN-International. J Archit Art Des* 2021;10:218–29.
- [16] Galloppo D, Mascitti J, Pietroni L. Design strategies for the development of life-saving furniture systems in the event of an earthquake. *WIT Trans Built Environ* 2019;189:67–77. <https://doi.org/10.2495/SAFE190071>.
- [17] Magliulo G, D'Angela D. Seismic response and capacity of inelastic acceleration-sensitive nonstructural elements subjected to building floor motions. *Earthq Engng Struct Dyn* 2024;eqe.4080. <https://doi.org/10.1002/eqe.4080>.
- [18] Kazantzi AK, Miranda E, Vamvatsikos D. Strength-reduction factors for the design of light nonstructural elements in buildings. *Earthq Engng Struct Dyn* 2020;49:1329–43. <https://doi.org/10.1002/eqe.3292>.
- [19] Chen MC, Pantoli E, Wang X, Astroza R, Ebrahimian H, Hutchinson TC, Conte JP, Restrepo JJ, Marin C, Walsh D, Bachman RE, Hoehler MS, Englekirk R, Faghihi M. Full-scale structural and nonstructural building system performance during earthquakes: part I – specimen description, test protocol, and structural response. *Earthq Spectra* 2016;32(2):737–70.
- [20] Di Sarno L, Magliulo G, D'Angela D, Cosenza E. Experimental assessment of the seismic performance of hospital cabinets using shake table testing. *Earthq Eng Struct Dyn* 2018;1–21.
- [21] Pürgstaller A, Gallo PQ, Pampanin S, Bergmeister K. Seismic demands on nonstructural components anchored to concrete accounting for structure-fastener-nonstructural interaction (SFNI). *Earthq Eng Struct Dyn* 2020;49:589–606.
- [22] Filiatrault A. Seismic evaluation of modular office furniture system. *Earthq Spectra* 1991;7(5):524–41.
- [23] Filiatrault A, Kuan S, Tremblay R. Shake table testing of bookcase – partition wall systems. *Can J Civ Eng* 2004;31:664–76.
- [24] FEMA E-74. Reducing the Risks of Nonstructural Earthquake Damage – A Practical Guide. Federal Emergency Management Agency, 2012.
- [25] Guide and checklist for Nonstructural Earthquake Hazards in California Schools. California Emergency Management Agency, 2011.
- [26] Case Studies of Seismic Nonstructural Retrofitting in School Facilities. National Institute for Educational Policy Research, Study Group Report on the "Investigative Research for Promoting the Seismic Retrofitting of School Facilities". Educational Facilities Research Center, 2005, Japan.
- [27] Scozzese F, Zona A, Dall'Asta A. Glass-aluminium partition walls with high-damping rubber devices: seismic design and numerical analyses. *Buildings* 2024;14(8):2445. <https://doi.org/10.3390/buildings14082445>.
- [28] Ministry of Infrastructure and Transport. 2018. NTC 2018. Aggiornamento delle "Norme Tecniche per le costruzioni" DM 17/01/2018 (in Italian).
- [29] D'Angela D, Magliulo G, Di Salvatore C, Zito M. Seismic assessment and qualification of acceleration-sensitive nonstructural elements through shake table testing: reliability of testing protocols and reliability-targeted safety factors. *Eng Struct* 2024. <https://doi.org/10.1016/j.engstruct.2023.117271>.