

Bulletin of Earthquake Engineering

A Probabilistic Investigation on the Dynamic Behaviour of Pile Foundations in Homogeneous Soils --Manuscript Draft--

Manuscript Number:	BEEE-D-21-00486R1
Full Title:	A Probabilistic Investigation on the Dynamic Behaviour of Pile Foundations in Homogeneous Soils
Article Type:	S.I. : Soil-Structure Interaction Effects on the Dynamics of Structures
Keywords:	Impedance functions, kinematic response factors, Pile foundations, Probabilistic analysis, Quasi random sampling, Sensitivity analysis, Soil-foundation system, Soil-Structure Interaction.
Corresponding Author:	Sandro Carbonari, Ph.D. Universita Politecnica delle Marche Ancona, ITALY
Corresponding Author Secondary Information:	
Corresponding Author's Institution:	Universita Politecnica delle Marche
Corresponding Author's Secondary Institution:	
First Author:	Lucia Minnucci, Ph.D.
First Author Secondary Information:	
Order of Authors:	Lucia Minnucci, Ph.D. Michele Morici, Ph.D. Sandro Carbonari, Ph.D. Francesca Dezi, Ph.D. Fabrizio Gara, Ph.D. Graziano Leoni, Ph.D.
Order of Authors Secondary Information:	
Funding Information:	
Abstract:	<p>Soil-structure interaction is a complex problem to address in structural design due to difficulties related to the modelling of the soil-foundation behaviour, which is frequency-dependent and affected by uncertainties. The substructure method is an efficient approach to include the soil-foundation behaviour in the superstructure response, since it allows addressing separately the soil-foundation and the superstructure analysis exploiting different tools and expertise. A deterministic approach is usually adopted for the soil-foundation system analysis selecting properties of foundation and soil based on an engineering judgment, despite uncertainties due to the intrinsic variability of soil parameters are largely recognised by both scholars and practitioners, as well as confirmed by experimental campaigns and laboratory tests. This paper presents a probabilistic perspective of the dynamic behaviour of pile foundations in homogeneous soils, focusing on the effects of the uncertainties in: (i) the frequency-dependent impedance functions; and (ii) the kinematic response factors necessary to derive the foundation input motion from the free-field motion. Single piles and square pile groups are considered. Uncertainties are described through the probabilistic distributions of parameters governing the soil-foundation dynamic response, while the samples are generated using the quasi-random sampling technique. Probabilistic analyses are performed utilizing an efficient numerical model that has been developed, and the variability of the output quantities is presented and discussed. The latter reveals to vary strongly with frequency. In addition, sensitivity analyses are performed to investigate the influence of each variable uncertainty on the system response. The response</p>

	quantities are highly sensitive to the shear wave velocity while the soil density and the pile elastic modulus may have a significant role, depending on the foundation layout.
Suggested Reviewers:	Ioannis Tsompanakis Technical University of Crete jt@science.tuc.gr Prof. Tsompanakis is an expert researcher in the field of soil-structure interaction and pile foundations.
	Harry Far University of Technology Sydney Harry.Far@uts.edu.au Prof. Far is an expert researcher in the field of structural engineering, including soil-structure interaction effects.
Response to Reviewers:	<p>Response to Reviewers' comments Ref.: BEEE-D-21-00486</p> <p>Title: A Probabilistic Investigation on the Dynamic Behaviour of Pile Foundations in Homogeneous Soils Authors: Minnucci L., Morici M., Carbonari. S., Dezi F., Gara F., Leoni G.</p> <p>The Authors thank the Reviewers for their positive feedback. The revised version of the above referenced manuscript has been prepared in order to address the editorial comments and the suggestions of Reviewer 1. The authors do their best to revise all the paper, trying to improve the English language, reducing long sentences, and using appropriate punctuation. In order to simplify the tracking of the changes, the revised version of the manuscript is attached with the added/extended/rewritten parts highlighted in yellow.</p> <p>Regarding the suggestion of including a notation list for acronyms, the authors think that, if added, it should include notations of equations, which is not typical for the journal and would elongate the manuscript.</p>

A Probabilistic Investigation on the Dynamic Behaviour of Pile Foundations in Homogeneous Soils

Minnucci Lucia¹, Morici Michele², Carbonari Sandro^{1*}, Dezi Francesca³, Gara Fabrizio¹, Leoni Graziano²

¹ *Università Politecnica delle Marche - DICEA Via Brecce Bianche, 60131 Ancona, Italy*

² *University of Camerino - SAAD Viale della Rimembranza, 63100, Ascoli Piceno, Italy*

³ *University of San Marino - DESD Via Consiglio dei Sessanta, 99 47891 Dogana – Repubblica di San Marino*

*Corresponding author: s.carbonari@univpm.it

ABSTRACT

Soil-structure interaction is a complex problem to address in structural design due to difficulties related to the modelling of the soil-foundation behaviour, which is frequency-dependent and affected by uncertainties. The substructure method is an efficient approach to include the soil-foundation behaviour in the superstructure response, since it allows addressing separately the soil-foundation and the superstructure analysis exploiting different tools and expertise. A deterministic approach is usually adopted for the soil-foundation system analysis selecting properties of foundation and soil based on an engineering judgment, despite uncertainties due to the intrinsic variability of soil parameters are largely recognised by both scholars and practitioners, as well as confirmed by experimental campaigns and laboratory tests. This paper presents a probabilistic perspective of the dynamic behaviour of pile foundations in homogeneous soils, focusing on the effects of the uncertainties in: (i) the frequency-dependent impedance functions; and (ii) the kinematic response factors necessary to derive the foundation input motion from the free-field motion. Single piles and square pile groups are considered. Uncertainties are described through the probabilistic distributions of parameters governing the soil-foundation dynamic response, while the samples are generated using the quasi-random sampling technique. Probabilistic analyses are performed utilizing an efficient numerical model that has been developed, and the variability of the output quantities is presented and discussed. The latter reveals to vary strongly with frequency. In addition, sensitivity analyses are performed to investigate the influence of each variable uncertainty on the system response. The response quantities are highly sensitive to the shear wave velocity while the soil density and the pile elastic modulus may have a significant role, depending on the foundation layout.

Keywords: Impedance functions, kinematic response factors, Pile foundations, Probabilistic analysis, Quasi random sampling, Sensitivity analysis, Soil-foundation system, Soil-Structure Interaction.

1 INTRODUCTION

Effects of Soil-Structure Interaction (SSI) on the seismic response of structural systems are widely studied in the literature [e.g., 1-4]. It is well recognized that, in case of deep foundations [e.g., 5-11], the interaction between piles and soil can cause detrimental consequences on the superstructure and the response from a fixed-base modelling could not be conservative. In order to properly include the effects of SSI, the substructure method [12] is one of the most common approaches adopted by both scientific community and practitioners due to its ease of application under the simplifying hypothesis of linear (or linear equivalent) behaviour for the soil-foundation sub-system [13]. The approach requires firstly the analysis of the soil-foundation system subjected to unit harmonic displacements, acting on a reference point of the foundation, to obtain the dynamic frequency-dependent impedance matrix. Subsequently, with the same model, the analysis of the soil-foundation system subjected to the propagation of seismic waves in the soil deposit (kinematic interaction) provides the Foundation Input Motion (FIM) (i.e., the displacements experienced by the foundation that actually differ from the free-field motion) and stresses in the foundation piles. The soil-foundation impedances are subsequently used to account for the foundation dynamic compliance in the inertial interaction analysis of

the superstructure subjected to the FIM. This analysis provides stresses in piles that have to be superimposed to the kinematic effects evaluated with the previous kinematic analysis.

Uncertainties in soil-foundation systems are often considered by engineers through an empirical approach based on assuming different extreme values for those parameters deemed to play a key role in the system response, and for which the on site investigation has shown a certain variability. This approach, based on the expert judgment and few analyses, try to treat uncertainties due to the spatial variability of the geological conditions, the limited number of measurements, and the errors of testing and measurement procedures. From a rigorous point of view, probabilistic analyses should be adopted to model uncertainties of parameters affecting the system behaviour and to evaluate the response scattering. With new computational capacities, the probabilistic approach is becoming a common practice in the research, when studying response of prototypal structural systems, or in the practice when analysing strategic structures. However, it is not yet common to adopt a full probabilistic perspective to approach the study of SSI phenomena. Lutes et al. [14] studied effects of soil and superstructure uncertainties on SSI of a shallow foundation, introducing a deterministic variability range on the nominal values of the soil shear stiffness, the soil Poisson's ratio, the superstructure shear stiffness and damping. Cottureau et al. [15] adopted a non-parametric approach [16-17] to construct a probabilistic model for impedance matrices; uncertainties are not defined for the soil-foundation system parameters and then propagated to impedances, but rather taken directly into account in the impedance matrices. Moghaddasi et al. [18] performed Monte Carlo simulations to evaluate the probabilistic seismic response of a single degree of freedom system, considering geometrical and mechanical uncertainties of both the soil-foundation system, represented through a shallow foundation frequency independent lumped parameter model, and the structure, assuming the random variables affecting the response to be uniformly distributed within selected ranges, covering a wide range of practical scenarios. However, to the best of the authors' knowledge, no detailed studies have been yet developed regarding the probabilistic dynamic behaviour of pile foundations, although the variability and uncertainties of the geotechnical properties play an important role in their dynamic response. Hence, the definition of probabilistic models describing the dynamic properties of the soil-foundation system needs further investigations in order to better address the effects of uncertainty relative to the soil and foundations on the superstructure response.

This paper presents the analysis of the dynamic behaviour of pile foundations in a probabilistic framework, in which uncertainties are accounted for through probabilistic distributions of the main parameters governing the soil-foundation dynamic response. Frequency dependent impedance functions of both single piles and square pile groups as well as kinematic response factors are investigated. By assuming uncorrelated probabilistic distributions for the selected random variables, samples are derived using the Quasi-Random Sampling (QRS) technique [19], which allows to obtain a reliable probabilistic distribution of the output quantities with low computational effort. Probabilistic analyses are performed by using a numerical model developed by the authors for the kinematic interaction analysis of single piles and pile groups [20]. The model accounts for the pile-soil-pile interaction, the soil hysteretic and radiation damping, which all affect the dynamic behaviour of deep foundations. The variability of the output quantities is presented and discussed. In addition, sensitivity studies are performed to illustrate the influence of variability of each considered random variable on the system response.

2 SOIL-FOUNDATION MODELLING AND UNCERTAINTIES

2.1 Modelling of the soil-pile foundation interaction

Many different models are available in the literature to evaluate the dynamic stiffness and the kinematic response of pile group foundations [20-25]. Among them, the numerical model proposed by Dezi et al. [20] permits to perform 3D kinematic interaction analyses of vertical and inclined piles, considered as elastic Euler-Bernoulli beam elements embedded in an infinite horizontally layered viscoelastic soil. Soil layers are assumed to be independent and the pile-soil-pile interactions at each layer is described by Green's functions derived in the frequency domain from the dynamics of oscillating rigid disks, accounting for both hysteretic and radiation damping [26-28]. An example of a pile group foundation and the relevant finite element model is depicted in

Figure 1. Because of the problem linearity, the dynamic equilibrium of a vertical pile foundation is expressed by the following complex valued system of linear algebraic equations in the frequency domain

$$\left(\mathbf{K}_p - \omega^2 \mathbf{M}_p + \mathbf{K}_s(\omega) \right) \mathbf{d}(\omega) = \mathbf{f}(\omega) \quad (1)$$

where \mathbf{K}_p and \mathbf{M}_p are the global stiffness and mass matrices of piles, respectively, $\mathbf{K}_s(\omega)$ is the impedance matrix of the soil, $\mathbf{d}(\omega)$ is the piles nodal displacement vector and $\mathbf{f}(\omega)$ is the vector of external loads due to the free-field motion and the pile-soil-pile interaction forces. The impedance matrix of the soil and the vector of external loads are obtained by assembling contributions of all the E elements as

$$\mathbf{K}_s(\omega) = \sum_{e=1}^E \int_0^{L_e} \mathbf{N}^T \mathbf{D}_s^{-1}(\omega, z) \mathbf{N} dz \quad (2a)$$

$$\mathbf{f}(\omega) = \sum_{e=1}^E \int_0^{L_e} \mathbf{N}^T \mathbf{D}_s^{-1}(\omega, z) \mathbf{u}_{ff} dz \quad (2b)$$

where L_e is the finite element length, \mathbf{N} is the matrix of the interpolating polynomials, \mathbf{u}_{ff} is the vector collecting the free-field motion components in the x , y and z directions (Figure 1b) while $\mathbf{D}_s(\omega, z)$ is the local soil-pile compliance matrix assembled considering Green's functions available in the literature [20].

The pile cap is modelled with a rigid body constraint applied to pile head nodes; the constraint Master node (M) has 6 degrees of freedom and is positioned at the centroid of the pile group at the level of the pile heads. By denoting the geometric matrix of the kinematic constraint by \mathbf{A} , Equation (1) assumes the form

$$\tilde{\mathbf{K}}(\omega) \tilde{\mathbf{d}}(\omega) = \tilde{\mathbf{f}}(\omega) \quad (3)$$

where

$$\tilde{\mathbf{K}}(\omega) = \mathbf{A}^T \left(\mathbf{K}_p - \omega^2 \mathbf{M}_p + \mathbf{K}_s(\omega) \right) \mathbf{A} \quad (4a)$$

$$\tilde{\mathbf{f}}(\omega) = \mathbf{A}^T \mathbf{f}(\omega) \quad (4b)$$

In Equation (3), $\tilde{\mathbf{d}}(\omega)$ is the vector collecting the six displacement components of M and the displacement components of the remaining non-constrained pile nodes. Equation (3) can be partitioned as follows to separate displacements of the master node (\mathbf{U}_M) from those of the embedded pile nodes (\mathbf{d}_S):

$$\begin{pmatrix} \tilde{\mathbf{K}}_{MM} & \tilde{\mathbf{K}}_{MS} \\ \tilde{\mathbf{K}}_{SM} & \tilde{\mathbf{K}}_{SS} \end{pmatrix} \begin{pmatrix} \mathbf{U}_M \\ \mathbf{d}_S \end{pmatrix} = \begin{pmatrix} \tilde{\mathbf{f}}_M \\ \tilde{\mathbf{f}}_S \end{pmatrix} \quad (5)$$

By condensing system (5) on the master node *dofs*, the following expressions for the complex impedance matrix (\mathfrak{Z}) and the complex FIM (\mathbf{U}_M) can be derived:

$$\mathfrak{Z}(\omega) = \left(\tilde{\mathbf{K}}_{MM} - \tilde{\mathbf{K}}_{MS} \tilde{\mathbf{K}}_{SS}^{-1} \tilde{\mathbf{K}}_{SM} \right) \quad (6a)$$

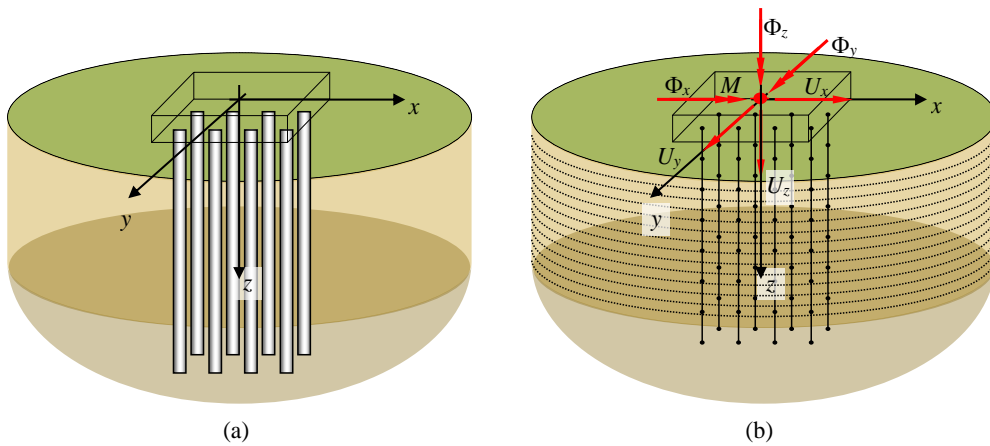

Figure 1. (a) Soil-foundation system; (b) FEM model.

$$\mathbf{U}_M(\omega) = \mathfrak{Z}^{-1}(\tilde{\mathbf{f}}_M - \tilde{\mathbf{K}}_{MS} \tilde{\mathbf{K}}_{SS}^{-1} \tilde{\mathbf{f}}_S) \quad (6b)$$

In case of double-symmetric pile configurations the impedance matrix has the form

$$\mathfrak{Z}(\omega) = \begin{bmatrix} \mathfrak{Z}_x & 0 & 0 & 0 & \mathfrak{Z}_{x-ry} & 0 \\ & \mathfrak{Z}_y & 0 & \mathfrak{Z}_{y-rx} & 0 & 0 \\ & & \mathfrak{Z}_z & 0 & 0 & 0 \\ & & & \mathfrak{Z}_{rx} & 0 & 0 \\ sym & & & & \mathfrak{Z}_{ry} & 0 \\ & & & & & \mathfrak{Z}_{rz} \end{bmatrix} \quad (7)$$

With reference to Figure 1b, $\mathfrak{Z}_x, \mathfrak{Z}_y, \mathfrak{Z}_z$ are the translational frequency dependent impedances along x, y and z , respectively, whereas $\mathfrak{Z}_{rx}, \mathfrak{Z}_{ry}, \mathfrak{Z}_{rz}$ are the rotational impedance components and $\mathfrak{Z}_{x-ry}, \mathfrak{Z}_{y-rx}$ are the coupled roto-translational terms.

Soil and pile material properties and geometric parameters are involved in the definition of the impedance matrix. The pile stiffness and mass matrices overall depend on the elastic modulus of the pile material, the pile diameter, and the pile length. The pile-soil-pile interaction, affecting the global dynamic stiffness matrix of the soil-foundation system and the external loads (Equation (2)), is captured by the soil compliance matrix $\mathbf{D}_s(\omega, z)$ that assumes the form

$$\mathbf{D}_s(\omega, z) = \begin{bmatrix} \mathbf{D}_{11} & \cdots & \mathbf{D}_{1q} & \cdots & \mathbf{D}_{1n} \\ \vdots & & \vdots & & \vdots \\ \mathbf{D}_{p1} & \cdots & \mathbf{D}_{pq} & \cdots & \mathbf{D}_{pn} \\ \vdots & & \vdots & & \vdots \\ \mathbf{D}_{n1} & \cdots & \mathbf{D}_{nq} & \cdots & \mathbf{D}_{nn} \end{bmatrix} \quad (8)$$

Sub-matrices $\mathbf{D}_{pq}(\omega, z)$ appearing in Equation (8) contain the elastodynamic Green's functions expressing the soil displacements at the location of the p -th pile at depth z , due to a time-harmonic unit point load acting at the location of the q -th pile at the same depth. They are expressed as

$$\mathbf{D}_{pq}(\omega, z) = \mathbf{G}_{pq}^T(z) \boldsymbol{\Psi}_{pq}(\omega, z) \mathbf{G}_{pq}(z) \mathfrak{D}(\omega, z) \quad (9)$$

where

$$\mathfrak{D}(\omega, z) = \begin{bmatrix} \frac{k_{\square}(\omega) - i\omega c_{\square}(\omega)}{k_{\square}^2(\omega) + \omega^2 c_{\square}^2(\omega)} & 0 & 0 \\ 0 & \frac{k_{\square}(\omega) - i\omega c_{\square}(\omega)}{k_{\square}^2(\omega) + \omega^2 c_{\square}^2(\omega)} & 0 \\ 0 & 0 & \frac{k_v(\omega) - i\omega c_v(\omega)}{k_v^2(\omega) + \omega^2 c_v^2(\omega)} \end{bmatrix} \quad (10)$$

collects soil displacements at the position of the applied force and matrix $\mathbf{G}_{pq}^T \boldsymbol{\Psi}_{pq} \mathbf{G}_{pq}$ describes the displacement attenuation from point q to point p within each layer [29-30]. Terms appearing in Equation (10) are formulated as follows [26-28]:

$$k_h = 1.67 E_s \left(\frac{E_p}{E_s} \right)^{-0.053} \quad (11a)$$

$$c_h(\omega) = \frac{1}{2} \pi d \rho_s V_s \left[\text{Re} \left(-i \frac{H_1^{(2)} \frac{\pi \omega d}{8V_s}}{H_0^{(2)} \frac{\pi \omega d}{8V_s}} \right) + \frac{V_c}{V_s} \text{Re} \left(-i \frac{H_1^{(2)} \frac{\pi \omega d}{8V_c}}{H_0^{(2)} \frac{\pi \omega d}{8V_c}} \right) \right] + 2\xi_s \frac{k_h}{\omega} \quad (11b)$$

$$k_v(\omega) = 0.6 E_s \left(1 + \frac{1}{2} \sqrt{\frac{\omega d}{V_s}} \right) \quad (11c)$$

$$c_v(\omega) = \pi d \rho_s V_s \left[\operatorname{Re} \left(-i \frac{H_1^{(2)} \frac{\pi \omega d}{8 V_s}}{H_0^{(2)} \frac{\pi \omega d}{8 V_s}} \right) \right] + 2 \xi_s \frac{k_v}{\omega} \quad (11d)$$

where E_p and E_s are the pile material and soil Young's modulus, respectively, while ξ_s is the hysteretic damping ratio of the soil. Furthermore, V_c is the velocity of the compression–extension waves, which can be expressed as a function of the shear wave velocity (Lysmer's analogue velocity), d is the pile diameter and $H_0^{(2)}$ and $H_1^{(2)}$ are the zero-order and first-order Hankel functions of second kind.

2.2 Probabilistic model

The research focuses on aleatoric uncertainties of mechanical parameters affecting the dynamic response of the soil-pile system. Epistemic uncertainties related to modelling are not investigated; however, limits of the adopted numerical model can be retrieved by referring to [20, 31-32] in which comparisons with results obtained from more refined modelling approaches and with available data from experimental tests are discussed.

The inherent variability of mechanical parameters gives rise to aleatoric uncertainties that can be characterized by statistical models and probabilistic laws. Several works from the geotechnical literature deal with the characterization of soil properties based on field tests, resulting in the definition of probabilistic trends for the density, the degree of saturation, the cohesion, the friction angle and many other features [33-35]. Concerning piles, variability of the parameters can be closely associated with the uncertainties on construction material properties. In particular, the use of concrete involves the adoption of probabilistic models regarding the compressive strength, density, and the elastic modulus, which are widely adopted in the literature [36-38]. Less important uncertainties usually characterise steel reinforcements whose behaviour is thus considered to be deterministic in this study. Since pile-soil-pile interaction phenomena are strongly affected by geotechnical parameters, which are sources of uncertainty, a probabilistic approach for the assessment of the soil-foundation system dynamic behaviour is necessary. Considering Equations (11), the soil density ρ_s , the shear wave velocity V_s and the concrete elastic modulus E_p are assumed as independent random variables. Probabilistic models assumed for above variables are deduced from the available technical literature. In particular:

- a normal distribution is considered for the soil density [39];
- a lognormal distribution is considered for the shear wave velocity [40-41];
- a lognormal distribution is considered for the cylindrical compressive concrete strength f_c [42] from which the elastic Young's modulus of the material is derived from [43]

$$E_p = 22000 \left(\frac{f_c + 8}{10} \right)^{0.3} \quad (12)$$

The remaining mechanical parameters, namely soil and concrete Poisson's ratios (ν_s, ν_p), soil and concrete damping ratios (ξ_s, ξ_p) and concrete density ρ_p , are assumed to be deterministic since their variability on the overall dynamic response of the foundation is limited under the assumption of linear soil behaviour [15, 44]. In fact, it is worth observing that most of the damping capacity of the soil-foundation system is attributable to radiation phenomena that are provided by the first addenda of Equations (11b) and (11d) as a function of the above defined random variables. For the purposes of this paper, by limiting furtherly the analysis to square pile groups, the problem previously stated can be turned in a non-dimensional form so that the impedance matrix in Equation (7) can be rewritten as

$$\mathbf{\Pi}(\rho_s, V_s, E_p; a_0) = \begin{bmatrix} \Pi_1 & 0 & 0 & 0 & \Pi_3 & 0 \\ & \Pi_1 & 0 & -\Pi_3 & 0 & 0 \\ & & \Pi_4 & 0 & 0 & 0 \\ & & & \Pi_2 & 0 & 0 \\ sym & & & & \Pi_2 & 0 \\ & & & & & \Pi_5 \end{bmatrix} \quad (13)$$

where ρ_s , V_s and E_p are parameters that are considered subjected to uncertainties,

$$a_0 = \frac{\omega d}{\mu_{V_s}} \quad (14)$$

is the non-dimensional frequency and

$$\Pi_1(\rho_s, V_s, E_p; a_0) = \frac{\Im_i}{\rho_s \mu_{V_s}^2 d} \quad \text{for } i = x, y \quad (15a)$$

$$\Pi_2(\rho_s, V_s, E_p; a_0) = \frac{\Im_{ri}}{\rho_s \mu_{V_s}^2 d^3} \quad \text{for } i = x, y \quad (15b)$$

$$\Pi_3(\rho_s, V_s, E_p; a_0) = \frac{\Im_{i-rj}}{\rho_s \mu_{V_s}^2 d^2} \quad \text{for } i = x, y \text{ and } j = y, x \quad (15c)$$

$$\Pi_4(\rho_s, V_s, E_p; a_0) = \frac{\Im_z}{\rho_s \mu_{V_s}^2 d} \quad (15d)$$

$$\Pi_5(\rho_s, V_s, E_p; a_0) = \frac{\Im_{rz}}{\rho_s \mu_{V_s}^2 d^3} \quad (15e)$$

In addition to the previous relationships relevant to the foundation dynamic compliance, transfer functions between the free field motion and the FIM can be considered to be representative for the foundation kinematic response. These are represented by ratios between FIM components and free field motion at the soil outcrop. By considering the earthquake shaking to be constituted by vertically travelling shear waves, because of the square layout of pile groups considered, the following transfer functions can be defined:

$$I_U(\rho_s, V_s, E_p; a_0) = \frac{U_i}{U_{ff,i}} \quad I_\Phi(\rho_s, V_s, E_p; a_0) = \frac{\Phi_i d}{U_{ff,i}} \quad \text{for } i = x, y \quad (16a, b)$$

where $U_{ff,x}$ and $U_{ff,y}$ are the free field displacements at the soil outcrop, and U_x, U_y, Φ_y and Φ_x are the translational and rotational non-null displacement components of the foundation Master node (M), respectively (Figure1b). Once suitable statistical distributions are adopted for the random variables ρ_s, V_s and E_p , Equations (15) and (16) will return impedances and transfer functions with their own distributions that are investigated in this paper.

2.3 Sensitivity index

Impedances Π_j ($j = 1, \dots, 5$) and kinematic transfer functions I_α , ($\alpha = U, \phi$), derived in the previous section, depend on the three independent aleatoric variables ρ_s, V_s and E_p , each characterised by a specific probability distribution. By denoting by Y the generic function and by X_k ($k = 1, \dots, 3$) the aleatoric variables, the following expression:

$$Y = g(X_1, X_2, X_3; a_0) \quad (17)$$

generically represents one of equations (15) and (16). To measure how uncertainties of the generic variable affect uncertainties of the model, the following sensitivity indexes can be considered

$$S_k(a_0) = \frac{V_{X_k}(E_{X \sim k}(Y|X_k))}{V(Y)} \quad (18)$$

where $V_{X_k}(E_{X \sim k}(Y|X_k))$ is the conditional variance of Y , and $V(Y)$ is the total variance. S_k is the first order sensitivity index of X_k [45] varying between 0 and 1; the higher the index, the higher the importance of the variable. As the considered variables are independent, the following relationship holds:

$$\sum_k S_k(a_0) = 1 \quad (19)$$

It is worth noticing that the adopted sensitivity indexes vary within the nondimensional frequency (a_0) range. In an attempt to measure the overall importance of the variable parameter over the frequency range $0 - A_0$ considered, the following mean value can be defined:

$$\bar{S}_k = \frac{1}{A_0} \int_0^{A_0} S_k(a_0) da_0 \quad (20)$$

which is also varying between 0 and 1 and satisfy condition analogous to Equation (19).

3 INVESTIGATED FOUNDATION SYSTEMS

Floating vertical piles embedded in a homogeneous soil deposit are considered; geometric parameters of foundations are assumed to be deterministic. Single piles, 2x2 and 3x3 square pile groups (Figure 2) are investigated. Two pile slenderness ratios L/d (representative of realistic short and long piles), and three pile spacing-diameter ratios s/d (consistently with realistic engineering applications) are considered for a total of 14 geometric models.

As discussed in section 2.2, soil density, shear wave velocity and concrete modulus of elasticity are considered to be aleatoric while the other mechanical parameters, necessary to define the model, are considered to be deterministic. Table 1 reports parameters (mean values and standard deviations) of the probability distributions adopted for the aleatoric parameters. In addition, Table 2 lists the deterministic values adopted for the other parameters.

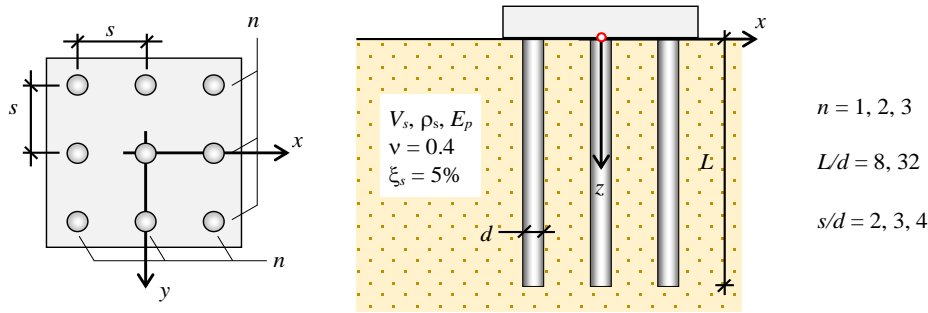

Figure 2. Scheme of investigated soil-foundation systems.

Table 1: Statistical distributions for ρ_s , V_s , E_c .

Uncertainties	Probabilistic Distribution	μ	σ
Soil density ρ_s [t/m^3]	Normal	1.75	$\sigma = 0.175$
Shear wave velocity V_s [m/s]	Lognormal	100, 200, 300	$\sigma_{ln} = 0.10$
Concrete cylindric strength [MPa]	Lognormal	20.12	$\sigma_{ln} = 0.20$

Table 2: Deterministic parameters.

Mechanical parameters	value
Soil Poisson's ratio ν_s [-]	0.40
Soil damping ξ_s [-]	0.05
Pile material Poisson's ratio (concrete) ν_p [-]	0.20
Pile material density (concrete) ρ_p [t/m^3]	2.50

3.1 Generation of samples

The Quasi-Random Sampling (QRS) technique, based on Sobol' Low Discrepancy Sequences (LDSs) [45-47], is adopted in this paper to generate samples that are not random, in the sense of completely unpredictable, but are generated progressively ensuring the selection of new points suitably kept away from previous selected ones. This approach allows reducing the generation of clusters (i.e. overlapping of samples) or gaps (i.e. empty spaces among samples) in the sample domain, assuring the minimum discrepancy, that is to place sample points as uniformly as possible in the variability domain.

The approach consists of the following main steps:

1. the QRS is used to generate two matrixes (A, B) each one collecting s triplets of the selected random variables (ρ_s, V_s, E_p);
2. three further matrixes C_k ($k = 1,2,3$) are generated by in turn replacing one column of A into the corresponding column of B (thus, $s \times 5$ triples constitute the sample domain).

Figure 3 presents the comparison between the classical Monte Carlo Simulation (MCS) sampling [48] and the QRS; Figure 3a shows that, in case of small sample sizes, MCS may generate important clusters or gaps (as can be observed from the 2D section of the sampling domain). On the contrary, the Sobol's LDS allows to obtain a good sample distribution in terms of discrepancy even for rather small numbers of simulations (Figure 3b). The efficiency of the QRS on the independent variables defined in the previous section was proven by the authors in [49] where the QRS is adopted to simulate the parameters variability for a single-pile foundation system. The probabilistic analysis is performed using triplets from A, B and C_i , and the results for each response quantity Y are collected in the corresponding 5 output vectors (of dimension s) for each frequency ($Y_A(a_0), Y_B(a_0), Y_{C_i}(a_0)$). Thanks to this partition of the output, instead of equation (18), the following formula can be adopted to compute the first order sensitivity index [46]:

$$S_k(a_0) = \frac{Y_A(a_0) \cdot Y_{C_k}(a_0) - f_0^2(a_0)}{Y_A(a_0) \cdot Y_A(a_0) - f_0^2(a_0)} \quad (21)$$

in which

$$f_0^2(a_0) = \left(\frac{1}{s} \sum_{i=1}^s Y_{A,i}(a_0) \right)^2 \quad (22)$$

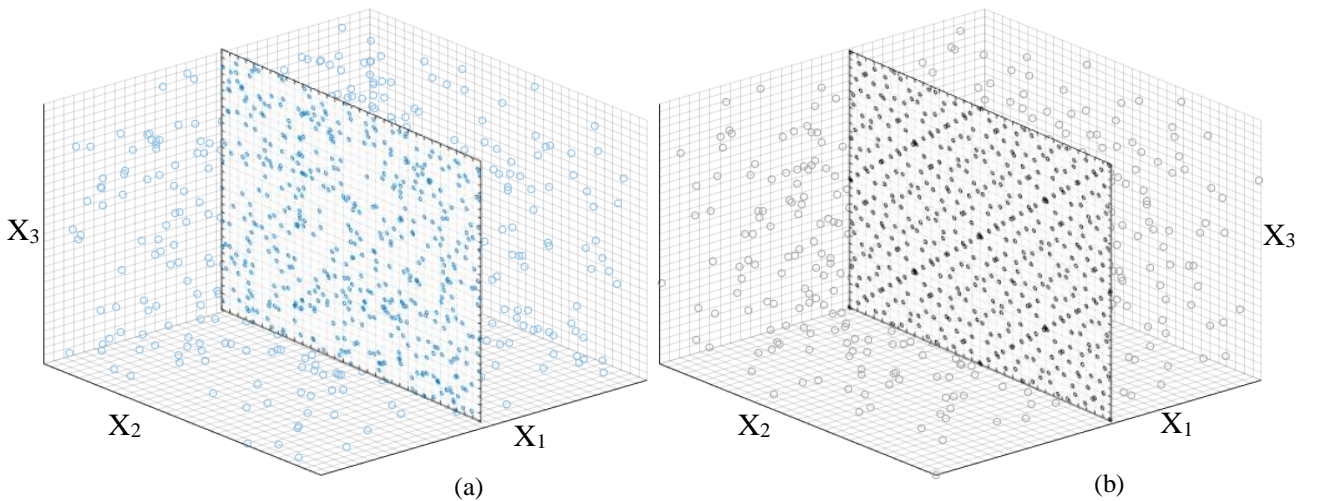

Figure 3. Comparison of samplings obtained with (a) MCS and (b) QRS Sobol' Sequence for 3 uniformly distributed random variables

The sample must be such that condition (19) is satisfied. In this work, $s = 2000$ is assumed, producing a sample of $N = 10.000$ elements. The parameter distributions obtained through the Sobol' QRS are shown in Figure 4 for the investigated random variables; in the same figure, the distributions relevant to a MCS are shown considering the same number of samples, demonstrating the potentials of the former approach to better fit the selected density functions.

4 RESULTS OF PROBABILISTIC SOIL-FOUNDATION DYNAMIC ANALYSES

In this section, results of the probabilistic soil-foundation dynamic analyses performed through the numerical model by Dezi et al. [20] are presented, focusing on the foundation impedance functions and the kinematic response factors. The latter provide a measure of the filtering effect induced by the deep foundation on the free-field motion and can be used to compute the FIM (Equation (6b)). Impedance functions and kinematic response factors are evaluated in the non-dimensional frequency range 0-1, which assures that the frequency range of practical interest (0-10 Hz) in the field of seismic engineering is included. As already mentioned, 10.000 samples are generated for each foundation layout and dynamic analyses are performed for an overall number of 420.000 simulations. As a result, probabilistic distributions of output quantities can be outlined, highlighting the variability of the impedance functions and the kinematic response factors for each foundation layout.

4.1 Variability of impedances

Given the circular frequency, discrete probability density curves are obtained by dividing the range of variability in a number of classes; the class density value is evaluated by dividing the number of realizations of the dataset falling in the class by the total number of samples (relative frequency) and by the width of the class. For the sake of brevity, the probability density functions of impedances are shown in this section for some foundation layouts discussing peculiar trends of results. A complete overview will be presented later focusing on the first two statistical moments. Unless otherwise specified, comments below can be considered of general validity and apply to all the investigated foundations.

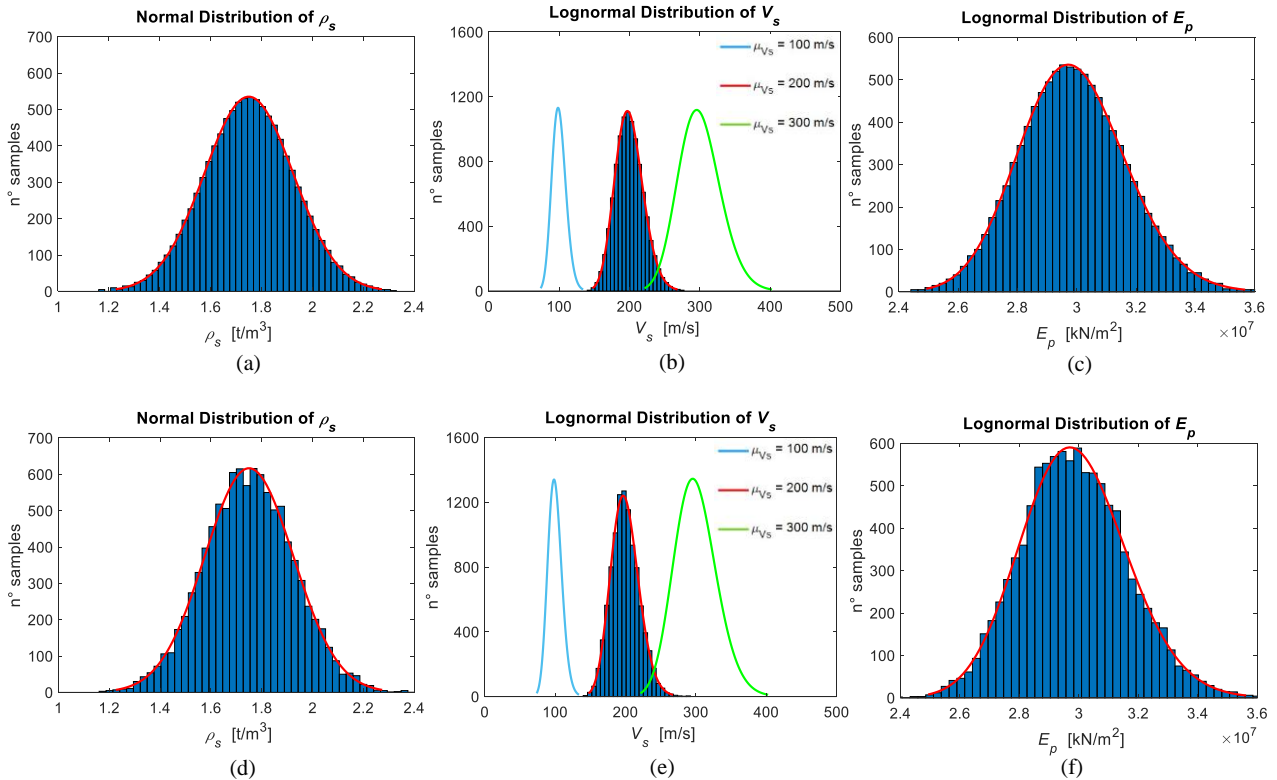

Figure 4. Sample distributions for the random variables: (a) ρ_s , (b) V_s and (c) E_p with Quasi Random technique; (d) ρ_s , (e) V_s and (f) E_p with Monte Carlo simulation.

Figure 5 shows the variability of the real and imaginary parts of the non-dimensional translation impedance Π_1 of the 2x2 foundation for $s/d = 4$, $L/d = 32$ and $V_s = 300$ m/s. In detail, Figure 5a shows a planar view of the frequency-dependent impedance function realizations. Plots represent the probability density by means of a colour scale (bright colours correspond to higher density values). In the same graph three significant quantities are highlighted to characterize the distribution in a probabilistic perspective: the red solid line fits the mean value of impedances, the red dashed curve is the median value and the dotted curve is the mode; furthermore 25th and 75th percentiles are reported. Figure 5b shows curves representing the density distribution of impedances for selected a_0 values (0, 0.25, 0.50, 0.75 and 1.00). Regarding real parts, it is worth observing that the data scattering, which is overall important, varies sensibly with frequency and presents a remarkable reduction in the 0.6-0.8 a_0 range. The mean and median curves are almost coincident within the investigated frequency range, while the mode curve differs sensibly from these at the higher frequencies. It is worth mentioning that data at 0 frequency provides the static stiffness of the soil-foundation system. Concerning imaginary parts, a trend can be recognised for the data dispersions: an overall increase of the scattering is observed by increasing the frequency.

Figure 6 presents the analysis outcomes of the vertical non-dimensional impedance Π_4 of the 3x3 foundation for $s/d = 3$, $L/d = 8$ and $V_s = 200$ m/s. For non-dimensional frequencies a_0 lower than 0.5 the data scattering is not significant; scattering increases repentantly at higher frequencies, especially for the imaginary parts for frequencies higher than 0.75, as clearly depicted in Figure 6b. Considerations about the mean value, the median and the mode of the previous case hold: the mean value practically coincides with both the median and the mode values up to $a_0 = 0.5$ for both the real and imaginary parts of the impedance component.

Similarly, Figure 7 refers to real and imaginary parts of rotational non-dimensional impedance Π_2 for the 2x2 foundation with $s/d = 2$, $L/d = 8$ and $V_s = 100$ m/s. Concerning trends of data scattering, the variability of real part reveals to be almost constant, holding a lognormal-like trend on the transverse probability distributions, while scattering of imaginary parts progressively increase with frequency.

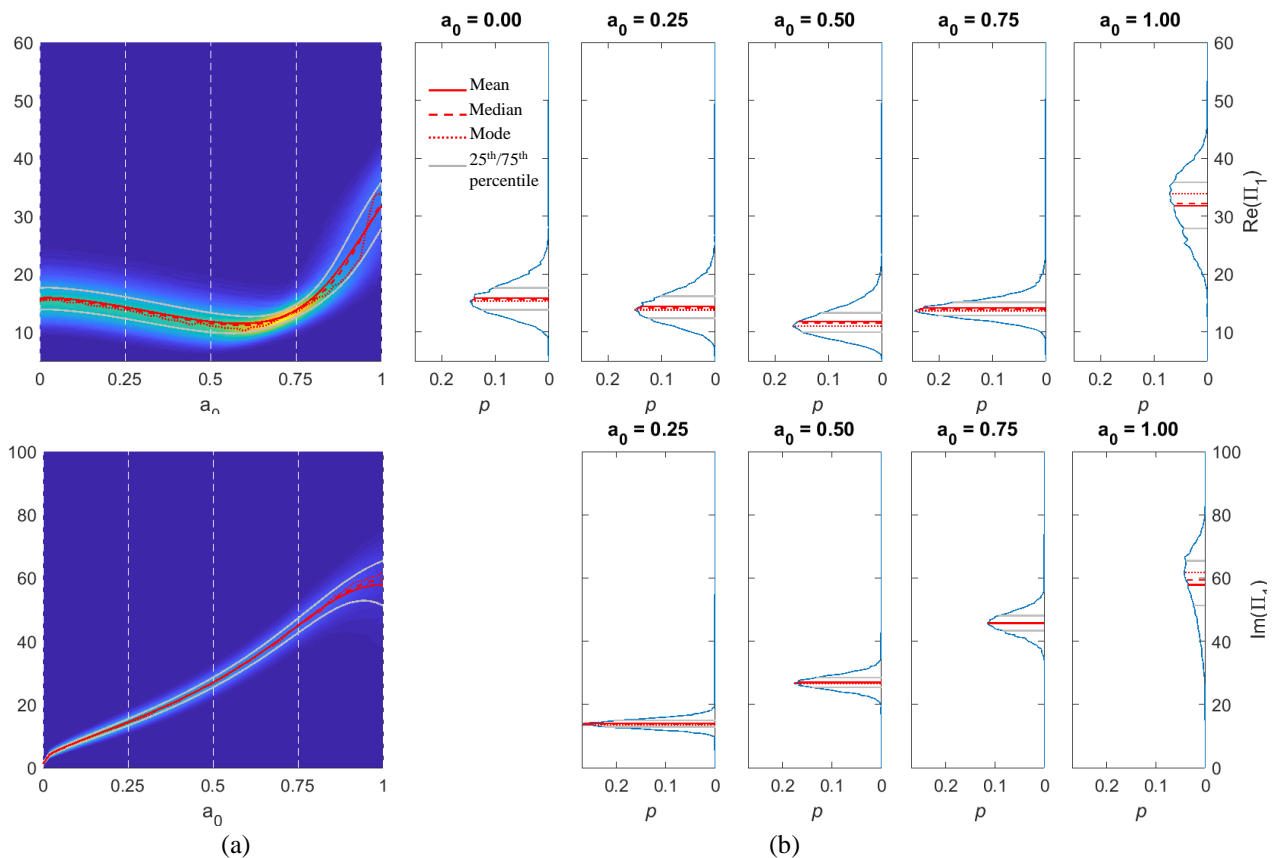

Figure 5. (a) Variability of Π_1 (real and imaginary parts) and (b) distributions of values at selected frequencies
Case 2X2, $s/d = 4$, $L/d = 32$, $V_s = 300$ m/s

From a qualitative point of view, previous considerations concerning the mean, mode and median values hold even if in this case, less important differences among them are obtained in the whole investigated frequency range.

Finally, Figure 8 shows the coupled non-dimensional roto-translational impedance Π_3 of the 3x3 foundation with $s/d = 4$, $L/d = 32$ and $V_s = 200$ m/s. As well known, the typical coupled behaviour of deep foundations stems from the equilibrium of kinematic bending moments at the pile heads, which are due to translations and are equilibrated by axial forces in piles; thus, variability of the coupled roto-translational impedance reflects those of translational and vertical ones. In this sense, similarities in the data scattering with respect to translational (Figure 5) and vertical (Figure 6) impedances are evident although the latter refer to different case studies. Results previously discussed can lead to a general observation: scattering of impedances are very important in the range of frequencies in which impedances are characterised by higher gradients. This is due to the fact that a variation of the aleatoric parameter produces a frequency shift of the impedance functions peaks.

A complete overview of results from case studies relevant to the single piles, the 2x2 and 3x3 pile groups is shown in the sequel in terms of the first two statistical moments (mean values, standard deviations) and the relevant Coefficient Of Variation (COV). Figure 9 refers to impedance functions of the investigated single piles. Comments on the effects of the L/d ratio and V_s are omitted since these are quite well known in the literature [e.g., 50, 51]. On the contrary, some comments about trends of standard deviations and COVs are provided. Standard deviations of all the impedance components present trends that reflect those of the mean values for both the real and imaginary parts. Thus, COVs are almost independent on the case study and are constant with frequency for both the real and imaginary parts of translational, vertical and coupled roto-translational impedances. Overall, real parts have higher COVs than imaginary parts with values of about 25%, 15% and 10% for the translational, coupled roto-translational and vertical impedances, respectively. COVs of the rotational impedance present different trends: higher values are obtained for short piles than for long ones and increase up to 40% by reducing the soil dynamic properties.

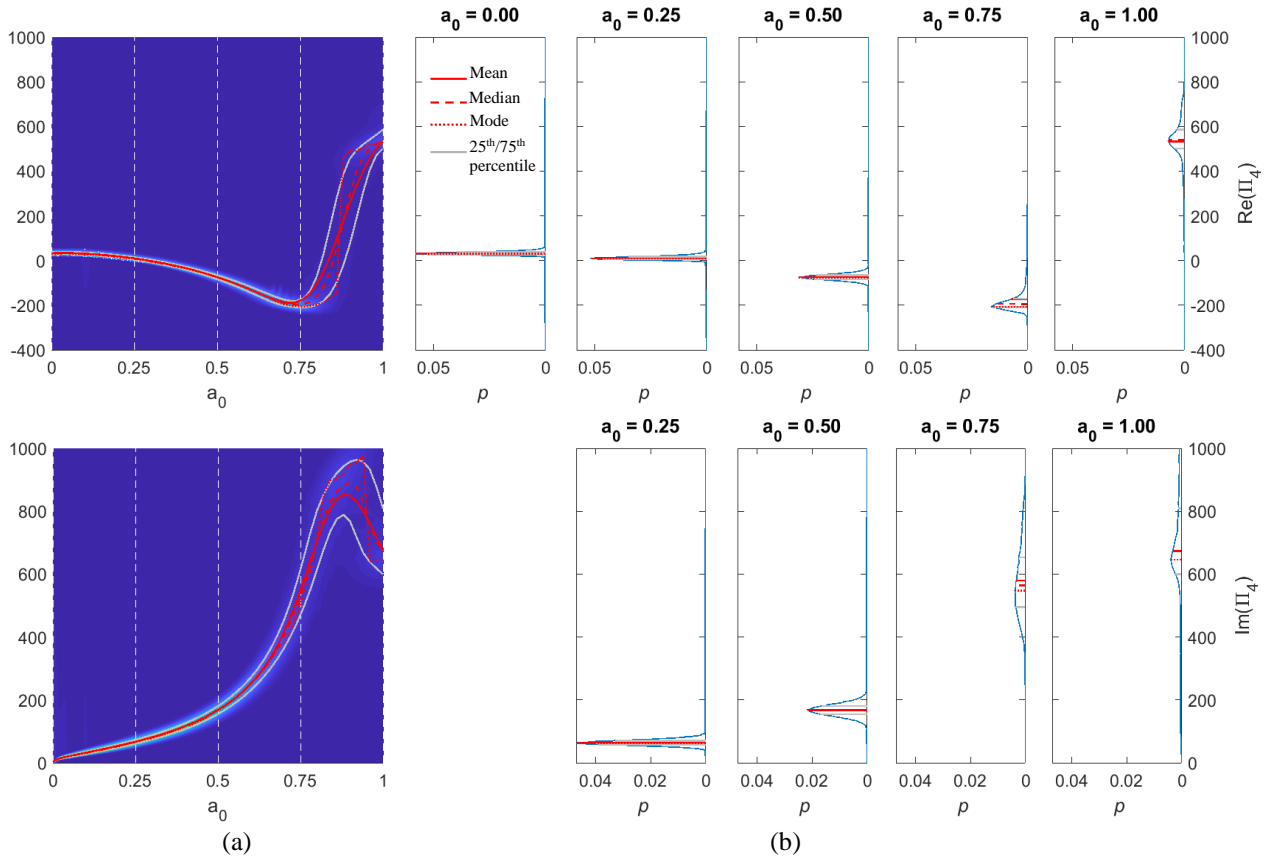

Figure 6. (a) Variability of Π_4 (real and imaginary parts) and (b) distributions of values at selected frequency values
Case 3x3, $s/d = 3$, $L/d = 8$, $V_s = 200$ m/s

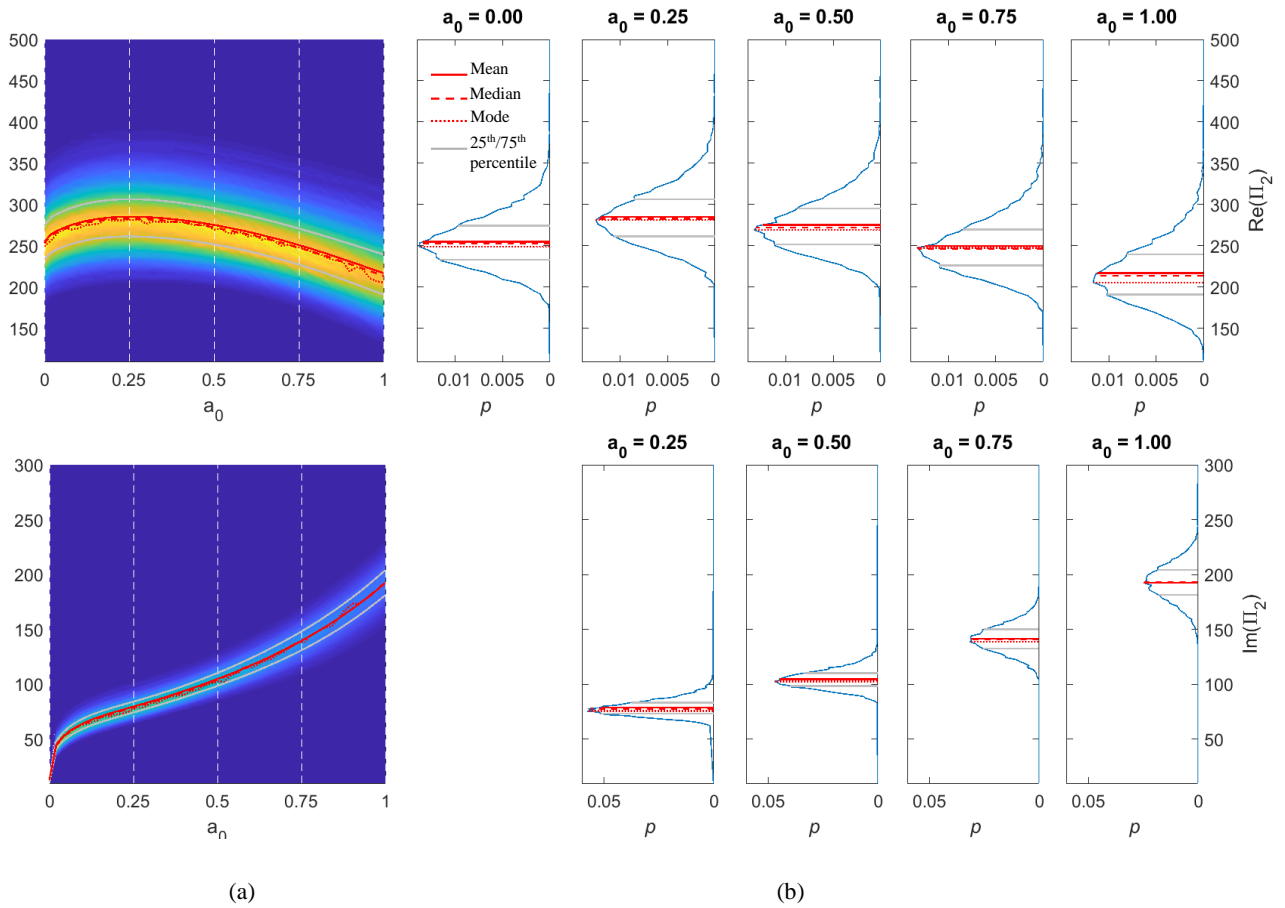

Figure 7. (a) Variability of Π_2 (real and imaginary parts) and (b) distributions of values at selected frequencies
Case 2x2, $s/d = 2$, $L/d = 8$, $V_s = 100$ m/s

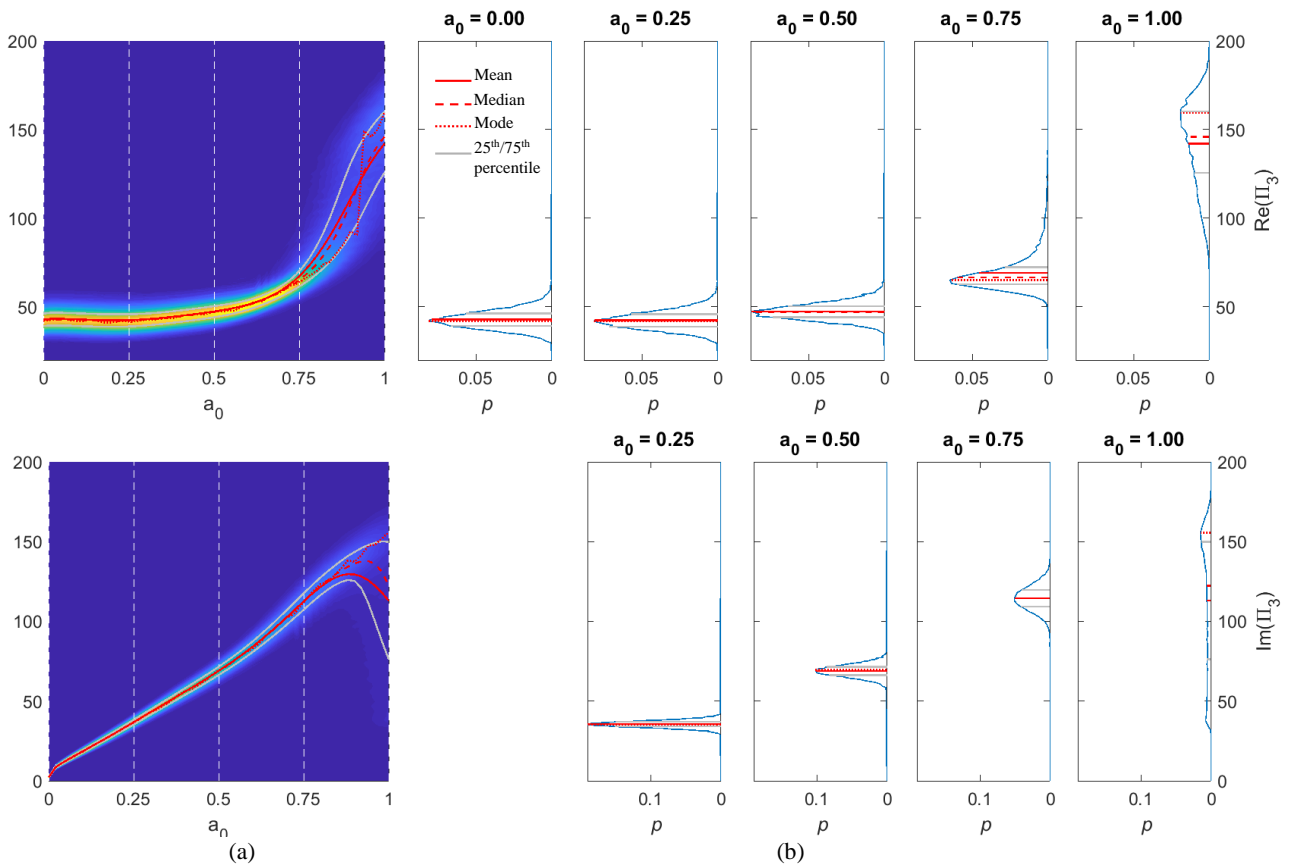

Figure 8. (a) Variability of Π_3 (real and imaginary parts) and (b) transverse distributions of values at selected frequency Case 3x3, $s/d = 4$, $L/d = 32$, $V_s = 200$ m/s

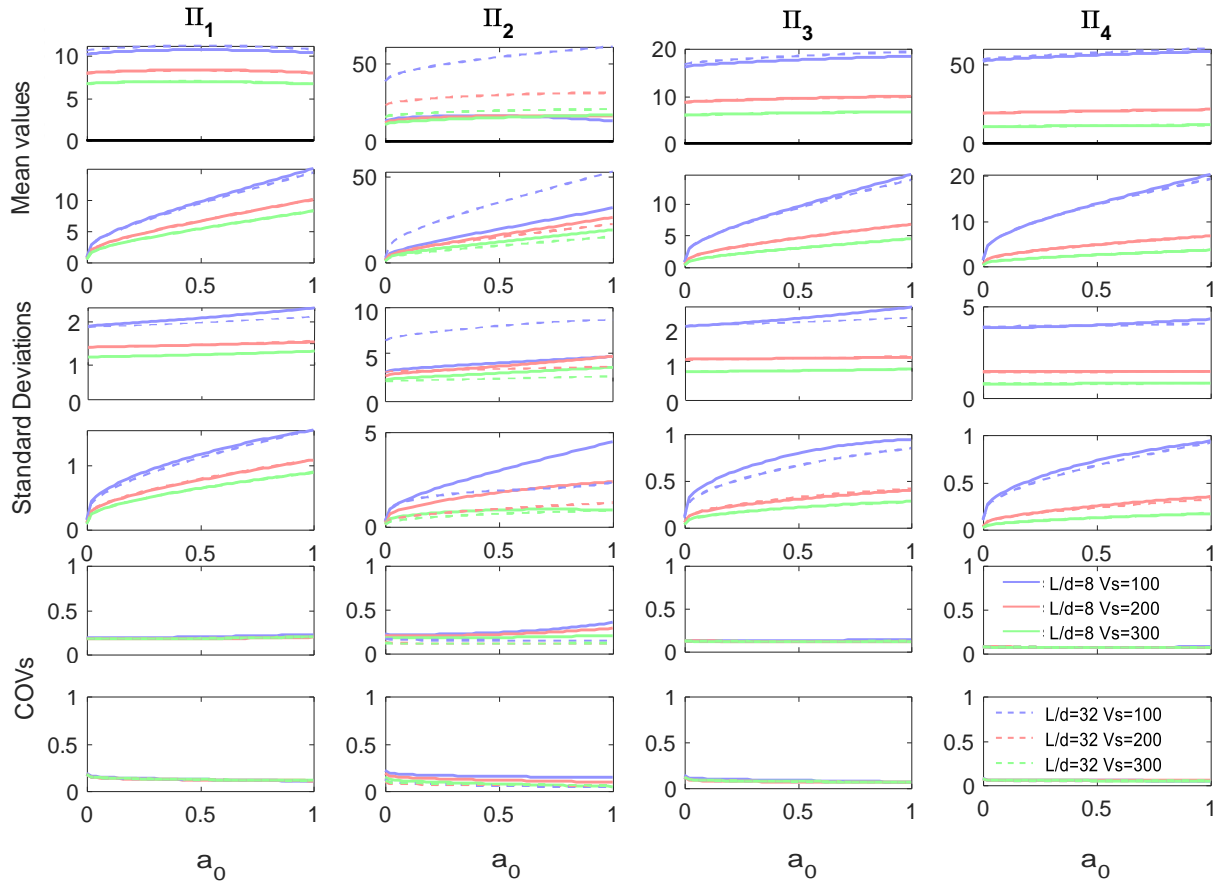

Figure 9. Frequency dependent mean values, standard deviations and COVs of real and imaginary parts of non-dimensional impedances of single piles

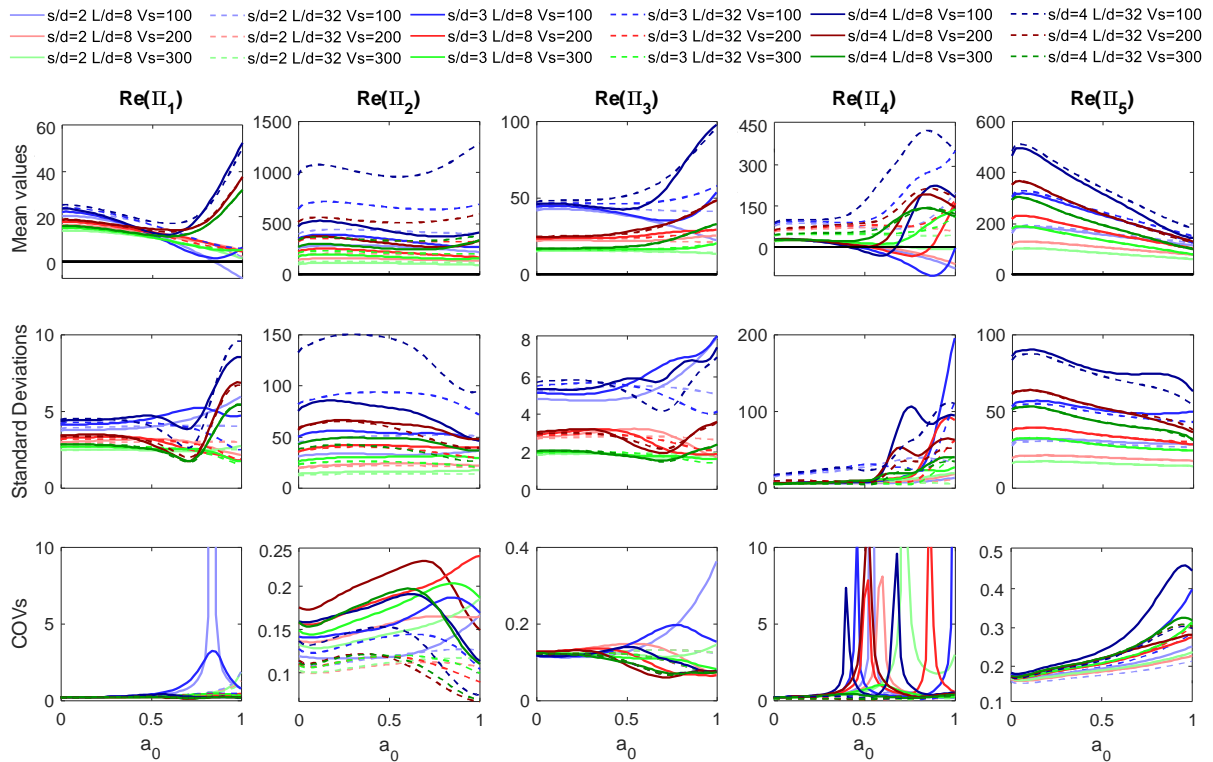

Figure 10. Frequency dependent mean values, standard deviations and COVs of real parts of non-dimensional impedances of 2x2 foundations

Figure 10 shows the frequency dependent mean values, standard deviations and the COVs of real part of the non-dimensional impedance functions of the 2x2 foundations. Effects of the s/d ratio and the soil stiffness on the mean values of impedances are thoroughly addressed in the literature [e.g., 5, 22, 24, 51-52]. Herein the variability and the scattering of results will be discussed: it can be observed that changes in the standard deviations are overall limited, particularly for the non-dimensional translational (Π_1) and vertical (Π_4) impedances for which COVs are within 15-20% up to a non-dimensional frequency of 0.5 and 0.3 for the translational and vertical components, respectively. For higher frequencies, COVs of both impedances are characterised by very high peaks due to the mean values approaching zero (resonance conditions); this phenomenon, which mainly affects foundations in soft soils for which the resonance condition occurs at lower frequencies, is important as uncertainties may reflect significantly on the response of the superstructure. The non-dimensional rotational impedance Π_2 and the coupled roto-translational impedance Π_3 are characterised by lower values of COVs in the whole frequency range, being within 25% and 40% respectively, with maximum values at higher frequencies ($a_0 > 0.5$). For Π_2 COVs of long piles are higher than those of short piles and increase with the s/d ratio. Finally, COVs of the torsional impedance Π_5 are the only one presenting a clear increasing trend with frequency passing from 10-20%, typical at lower frequencies, to 30-40% at higher frequencies.

Figure 11 shows quantities relevant to the imaginary components of impedances. Mean values show the typical increasing trend with frequency, characterised in some cases by peaks that for the highest s/d ratio fall within the investigated non-dimensional frequency range. Differently from mean values, standard deviations are almost constant in the frequency range 0-0.5 for all the impedance components (excepting for the static values, presenting very low standard deviations); for frequencies higher than 0.5, standard deviations increase rapidly and almost linearly with frequency. This feature produces the peculiar convex trends of the COVs, which decrease in the frequency range 0-0.5 and increase for higher frequencies. It is worth observing that COVs are included in the range 5-20% (up to 80% for the vertical component, only for $a_0 \geq 0.75$), excepting static or quasi-static values, which do not deserve attention since the mean values of imaginary parts of impedances tend to zero.

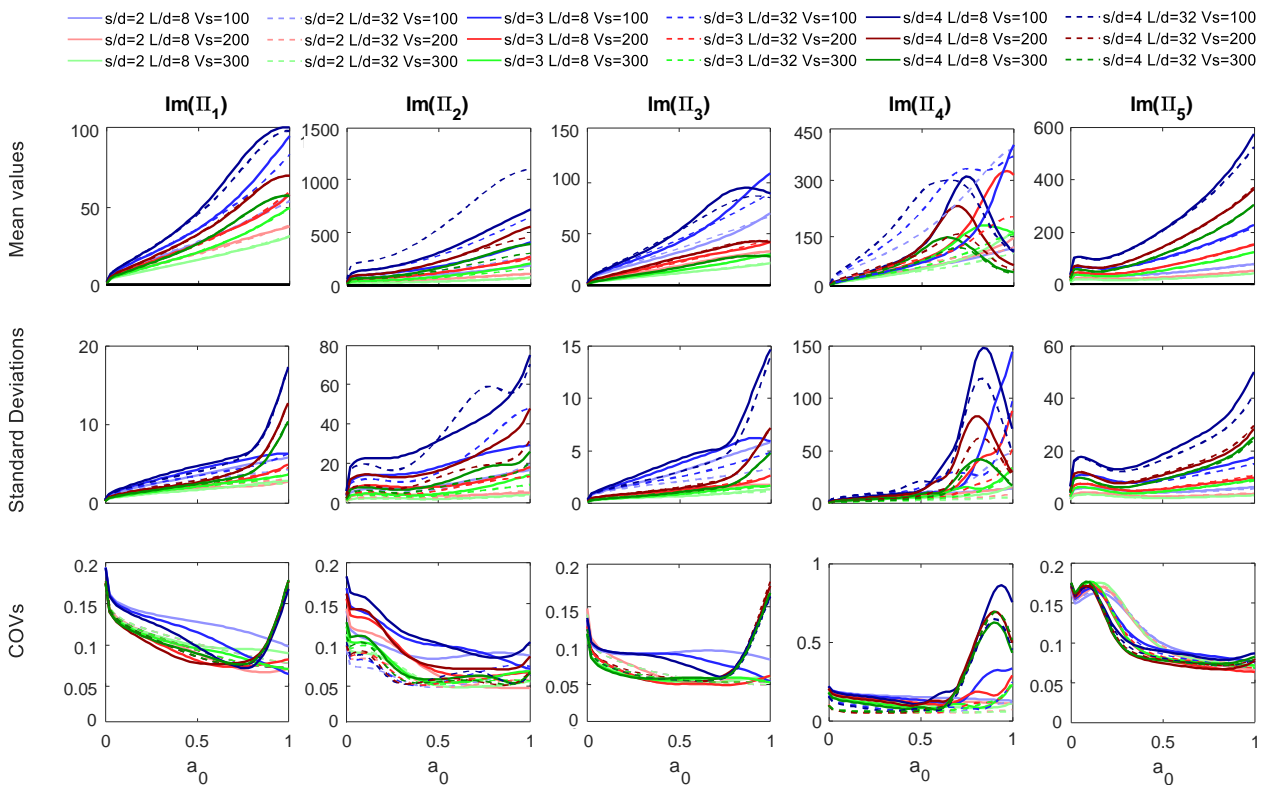

Figure 11. Frequency dependent mean values, standard deviations and COVs of imaginary parts of non-dimensional impedances of 2x2 foundations

With reference to the 3x3 foundations, Figure 12 shows the same quantities already presented. At a glance, similarities with results of the 2x2 foundations can be recognised. For example, standard deviations for the non-dimensional translational (Π_1) and vertical (Π_4) impedances are overall limited up to a non-dimensional frequency of 0.5 and 0.2 for the translational and vertical components, respectively. Again, at higher frequencies, COVs are characterised by peaks due to nearly null mean values; it is worth noting that these phenomena occur at lower frequencies with respect to 2x2 foundations and affect a higher number of investigated foundations. Trends of COVs (within 20%) of the non-dimensional rotational impedance Π_2 and the coupled roto-translational impedance Π_3 are similar to those observed for the 2x2 foundations (excluding cases producing peaks). Finally, differently from 2x2 foundations, COVs of torsional impedance Π_5 present a constant trend at 20% on the entire frequency range; previous considerations about the peaks hold.

Figure 13 shows quantities relevant to the imaginary components. In this case, similarities with results from 2x2 foundations can be found concerning trends of mean, standard deviations and COVs, but larger variations at higher frequencies ($a_0 > 0.5$) are evident on standard deviations and COVs of Π_2 and Π_3 , with maximum COVs two and three times higher than those of the 2x2 foundations, respectively.

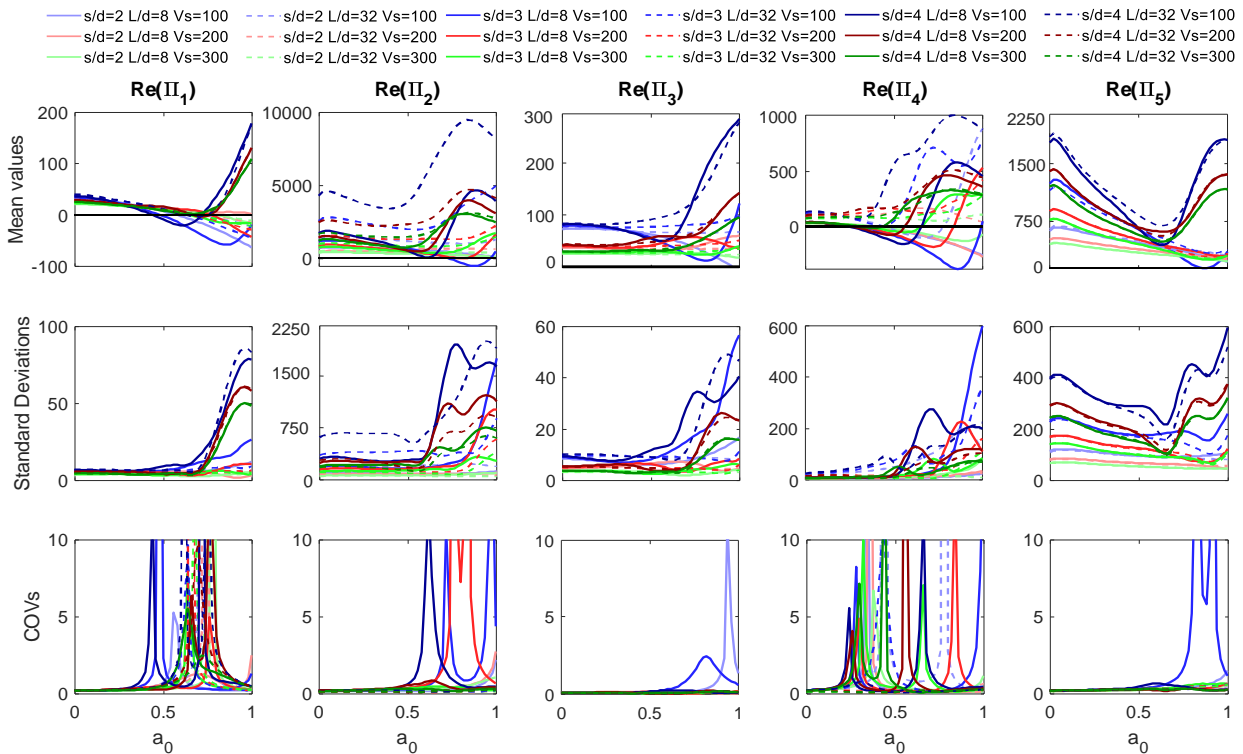

Figure 12. Frequency dependent mean values, standard deviations and COVs of real parts of non-dimensional impedances of 3x3 foundations

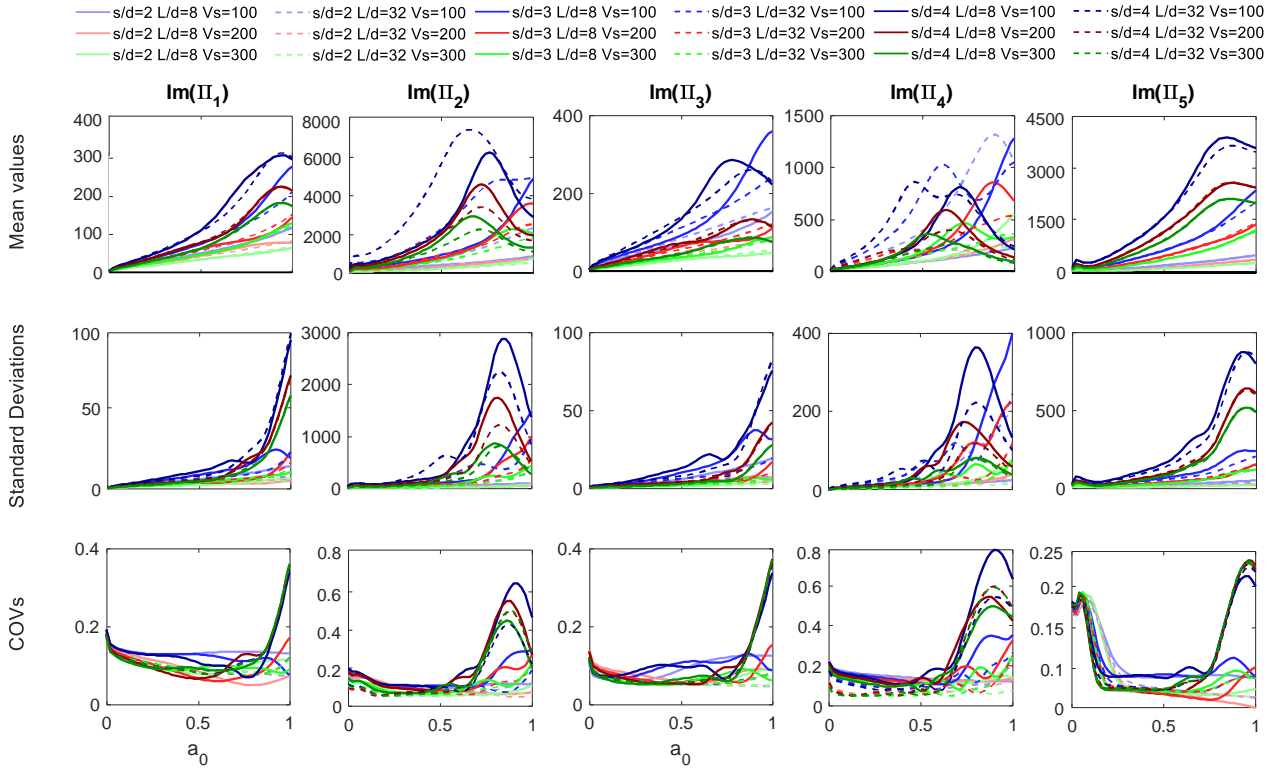

Figure 13. Frequency dependent mean values, standard deviations and COVs of imaginary parts of non-dimensional impedances of 3x3 foundations

4.1.1. Sensitivity indexes

In this section the first order sensitivity indexes \bar{S}_k for ρ_s , V_s and E_p are presented and discussed. Bar charts in

Table 3 collects the sensitivity indexes of all the single pile case studies. From an overall point of view, V_s is primarily responsible for the global variability of the results. Overall, for real parts sensitivity indexes of V_s are about 0.80 in all the considered pile configurations, expecting for the rotational component Π_2 , where the influence of the pile elastic modulus is similar to that of the shear wave velocity. This is because, differently from pile groups, the rotational stiffness of the single pile is strongly dependent on the pile elastic modulus (and the cross-section inertia properties). As for the imaginary parts, it can be observed that the sensitivity indexes of the soil density increase for the translational impedance Π_1 and the vertical impedance Π_4 ; V_s is no more the primarily responsible of the results variability. Also, the pile elastic modulus seems to play a significant role in the vertical impedance Π_4 (especially for long piles in soft soils) and a very important role for the rotational **component Π_2 (with sensitivity indexes up to 0.8) for which**, on the contrary, uncertainties on V_s have practically no implications on the results variability.

Bar charts in Table 4 and Table 5 depict the sensitivity indexes of **2x2 and 3x3 foundations**. Comments on pile groups are provided together since they present similarities. Concerning real parts of impedances, for both 2x2 and 3x3 pile foundations, very high values of the V_s sensitivity indexes can be found for Π_1 and Π_5 for all the case studies (in the range 0.75-0.90), while Π_2 , Π_3 and Π_4 are slightly more sensitive to the effect of the other parameters variability, especially the soil density. The pile elastic modulus has a limited impact, mainly on the rotational (Π_2), coupled roto-translational (Π_3), and vertical (Π_4) components of the impedance matrix (the latter only in the case of long piles). As for imaginary parts, a different behaviour can be delineated; it is interesting to observe the overall higher influence of the soil density for all the impedance components; in detail, the sensitivity indexes of the soil density became comparable or even higher than those of the shear wave velocity, especially for the coupled roto-translational (Π_3) and torsional (Π_5) terms. **Conversely**, the variability of E_p scarcely contributes to the variability of the translation (Π_1) and torsional impedances (Π_5); for the rotational (Π_2), the coupled roto-translational (Π_3) and the vertical (Π_4) impedances E_p sensitivity indexes up to 0.3 are observed in some cases.

Table 3: Sensitivity indexes for single piles.

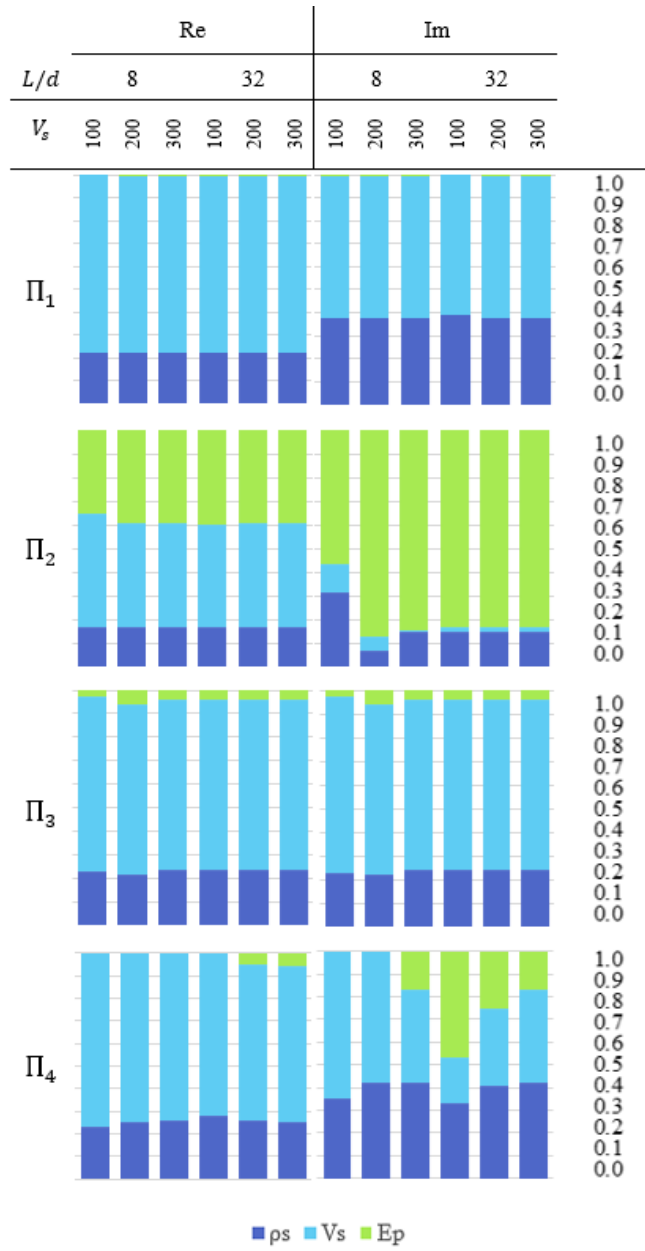

Table 4: Sensitivity indexes for 2x2 foundations.

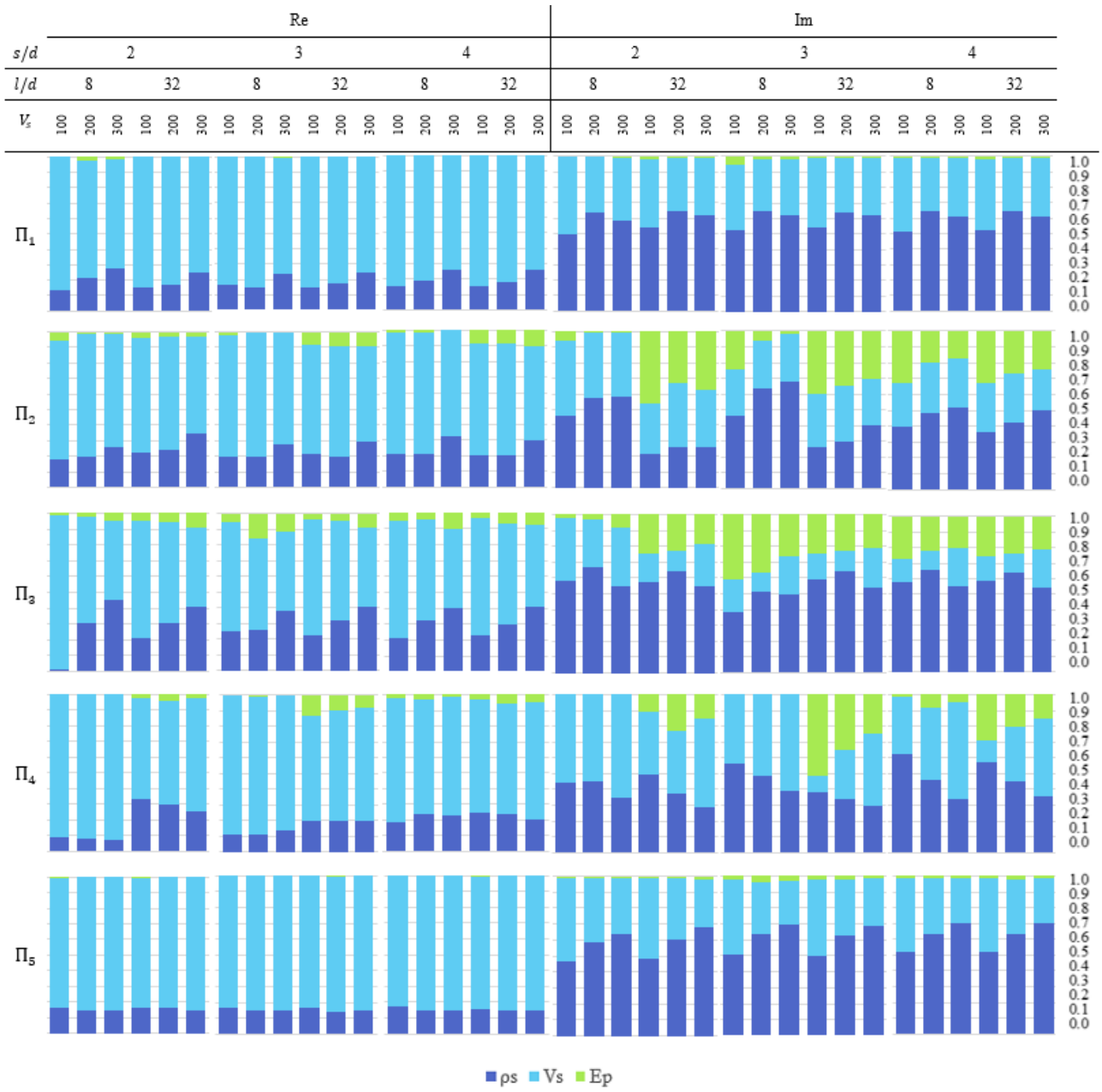
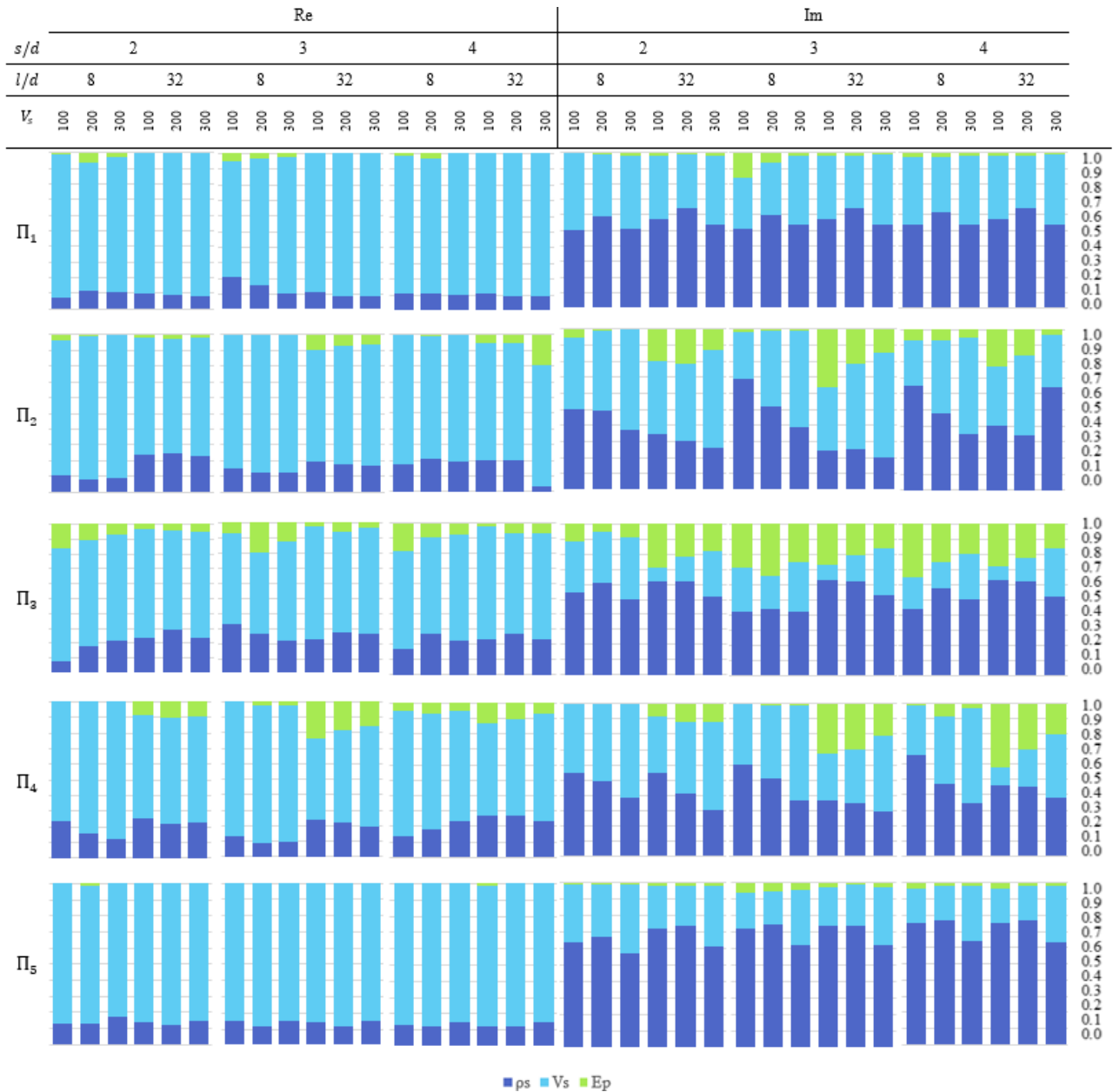

Table 5: Sensitivity indexes for 3x3 foundations.



4.2 Variability of kinematic response factors

In this section the variability of the Foundation Input Motion (FIM) given that of the random variables is addressed and discussed. Typical trends of the kinematic translational and rotational response factors are shown in Figure 14 for a set of samples from a 2x2 foundation layout (curves obtained from mean values of the probabilistic variables are in black line). Apart the very high variability of results, which will be addressed in the sequel, it can be observed that typical trends of the translational factor are characterised by a plateau of unit value extending up to a frequency that depends on the soil shear wave velocity (the higher the soil shear wave velocity, the higher the plateau extension is), followed by a rapid reduction and by a subsequent oscillation around a mean almost constant value. Furthermore, values greater than one 1 (up to 1.2) can be obtained for very stiff soils. On the contrary, the rotational kinematic response factor assumes nearly zero values at very low frequencies and increases rapidly with frequency presenting oscillations for higher frequencies, similarly to the translational parameter. Above trends, which are well known in the literature [53], determine intrinsic difficulties in the identification of probabilistic models for the kinematic parameters since oscillations of curves, characterised by peaks shifted in frequency, produce density probability distributions with non-usual shapes, making the fitting with conventional probability density functions a non-sense.

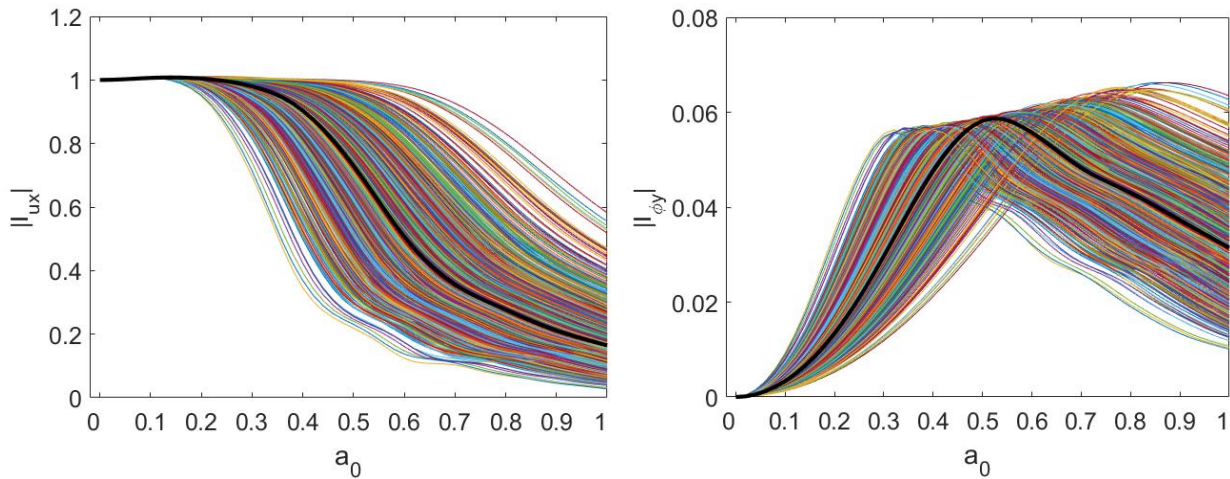

Figure 14. Typical trends of kinematic response factors (samples from case 2x2, $s/d = 4$, $L/d = 32$, $V_s = 100$ m/s). The black curves represent the kinematic response factors relative to the mean values of the sampling.

Results are presented adopting the approach used in the previous section for impedances. Figure 15 and Figure 16 show the variability of the translational (I_U) and rotational (I_ϕ) kinematic response factors for two 2x2 and 3x3 foundations, being possible a generalization of comments concerning the main statistical parameters and the results scattering. Differently from impedances, a small range at low non-dimensional frequency (0-0.25) can be identified in which the results dispersion of the translational factor is almost negligible and the parameter can be described by its mean value; this is because, as already stated, at low frequencies the translational parameter is almost unitary. Overall, for $a_0 > 0.25$, the variability of I_U generally increases with frequency, consistently with the parameter decrement. This phenomenon, already observed for impedances, confirms that the higher the gradient of the curves with frequency, the higher the dispersion of the parameter is. The rotational kinematic response factor I_ϕ also presents dispersions that follow the above rule. The density distributions at specific non-dimensional frequencies (0, 0.25, 0.50, 0.75 and 1.00), reported in Figure 15b and Figure 16b, confirm the dependence of the results scattering with the gradient of the function of the kinematic parameter. These phenomena are particularly evident for the 3x3 foundation where the mode of both the translational and rotational kinematic response factors presents jumps due to the strong variation of the data scattering with frequency, which is a consequence of the typical trends of the kinematic interaction parameters characterised by peaks (that naturally produces frequency ranges with high and low gradients of the kinematic response functions). Jumps in the mode values highlight that for certain frequencies the distributions can be bimodal with the most probable responses far from the mean one. Finally, the density distribution in Figure 15b and Figure 16b demonstrates the absence of a clear trend and the practical difficulty to define a probabilistic model for the parameter, at least for certain frequency ranges.

The first two statistical moments and the relevant COVs of the two kinematic response factors are discussed to provide a complete survey on the analysis results. Figure 17a refers to the investigated single piles; overall mean values present trends, with respect to V_s and L/d , that are well known from the technical literature and commenting about these goes beyond the aim of the paper. In contrast, it is worth discussing about COVs that, for the translational factor, remain constant with negligible oscillations around zero up to $a_0 = 0.4$, and then increase significantly and almost linearly with frequency with a gradient that depends on the shear wave velocity (the gradient reduces by increasing the soil shear wave velocity). Concerning the rotational parameters, mean values increase up to stabilise at $a_0 > 0.6$, 0.75 and 0.9 for $V_s = 100$, 200 and 300 m/s respectively, while standard deviations present an inflection point with an overall increasing trend in the whole frequency range. Consequently, COVs are characterised by a concave trend with the highest values ranging between 30-40%. It is both observing that above comments are in line with phenomena described in the previous paragraph for the two selected pile groups.

Figure 17b and Figure 17c, referring to 2x2 and 3x3 pile groups, respectively, are discussed together in view of their similarities in terms of results variability. Data relevant to the whole case studies confirm previous considerations: standard deviations of the translational kinematic response factors, and the relevant COVs, are

very small in the low non-dimensional frequency range 0-0.25 while both increase for higher frequencies. With reference to the rotational factor, trends of standard deviations are quite similar to that of the mean values and COVs are almost constant with frequency, ranging between 10-40%.

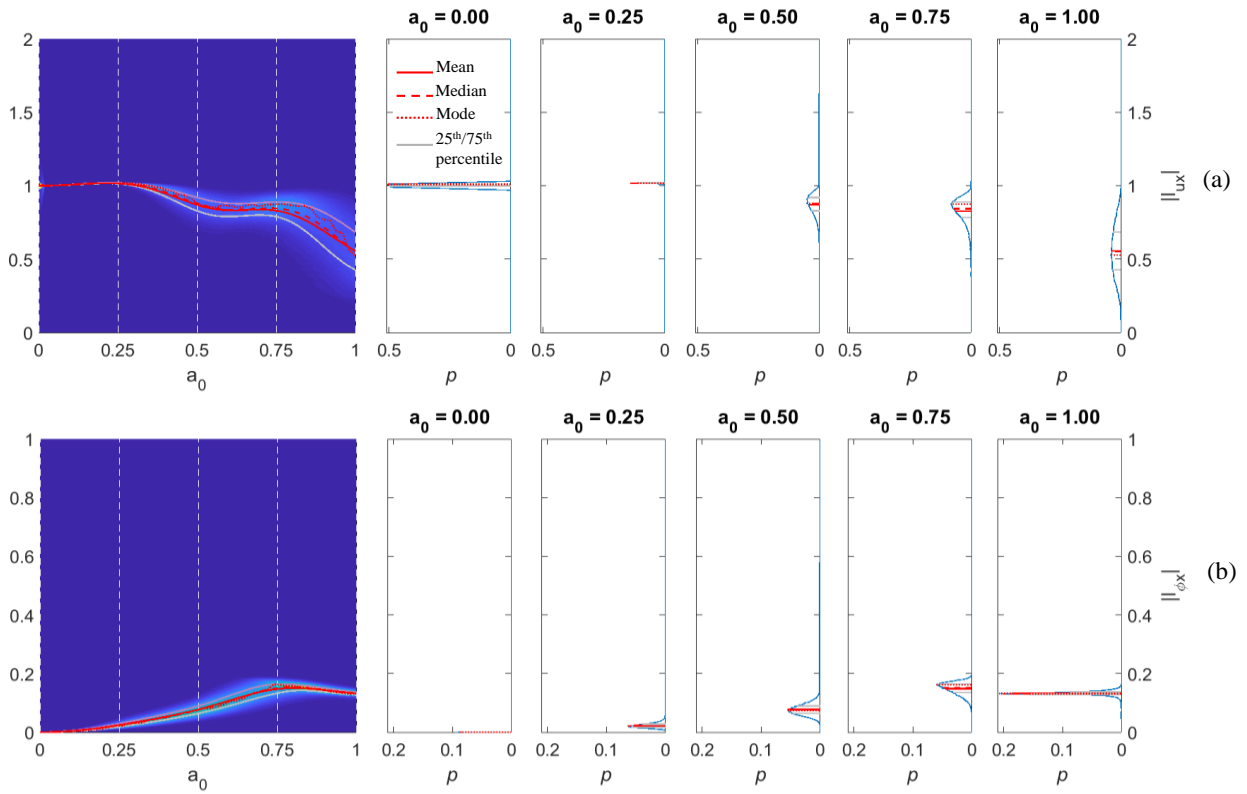

Figure 15. Variability of (a) I_U and (b) I_{ϕ} for 2x2 foundation, $s/d = 3$, $L/d = 8$, $V_s = 200$ m/s

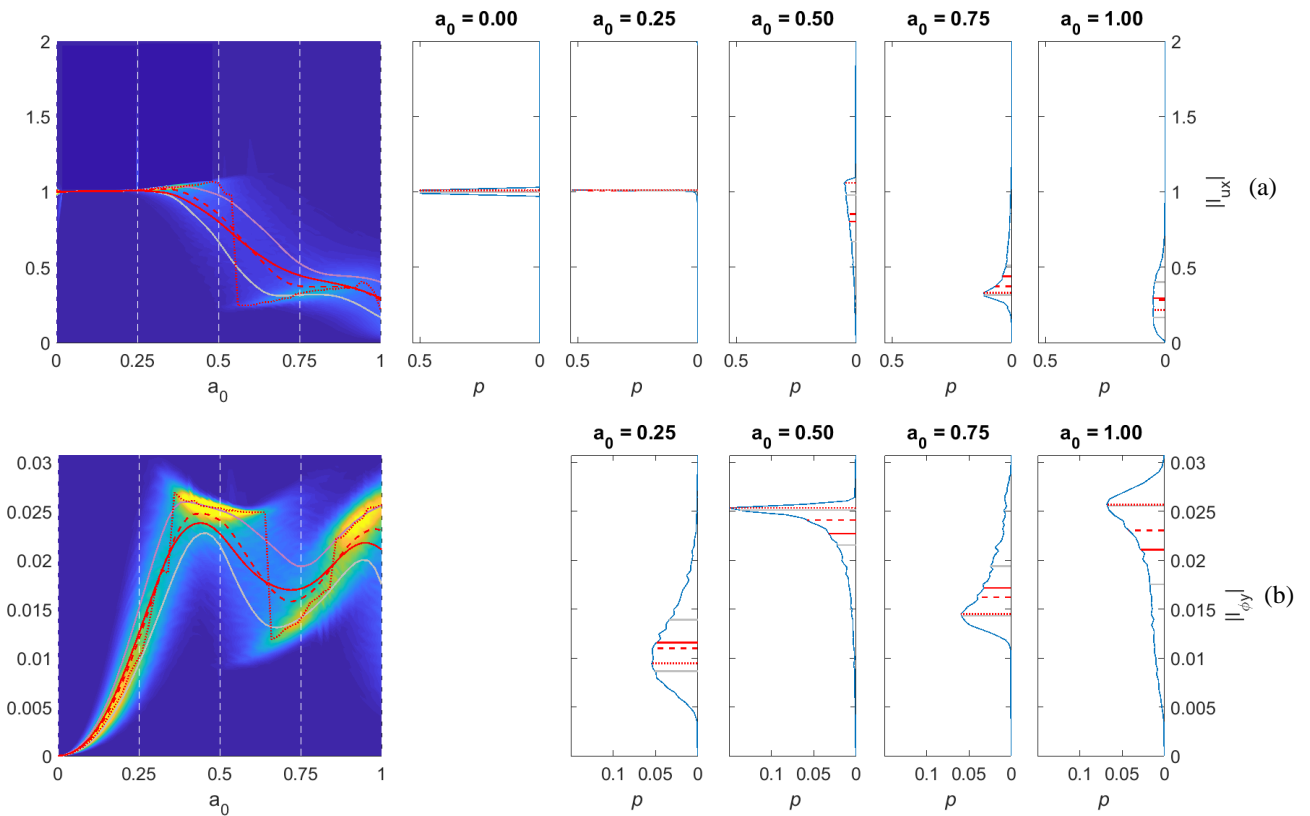

Figure 16. Variability of (a) I_{ij} and (b) I_{ϕ} for 3x3 foundation, $s/d = 4$, $L/d = 32$, $V_s = 100$ m/s

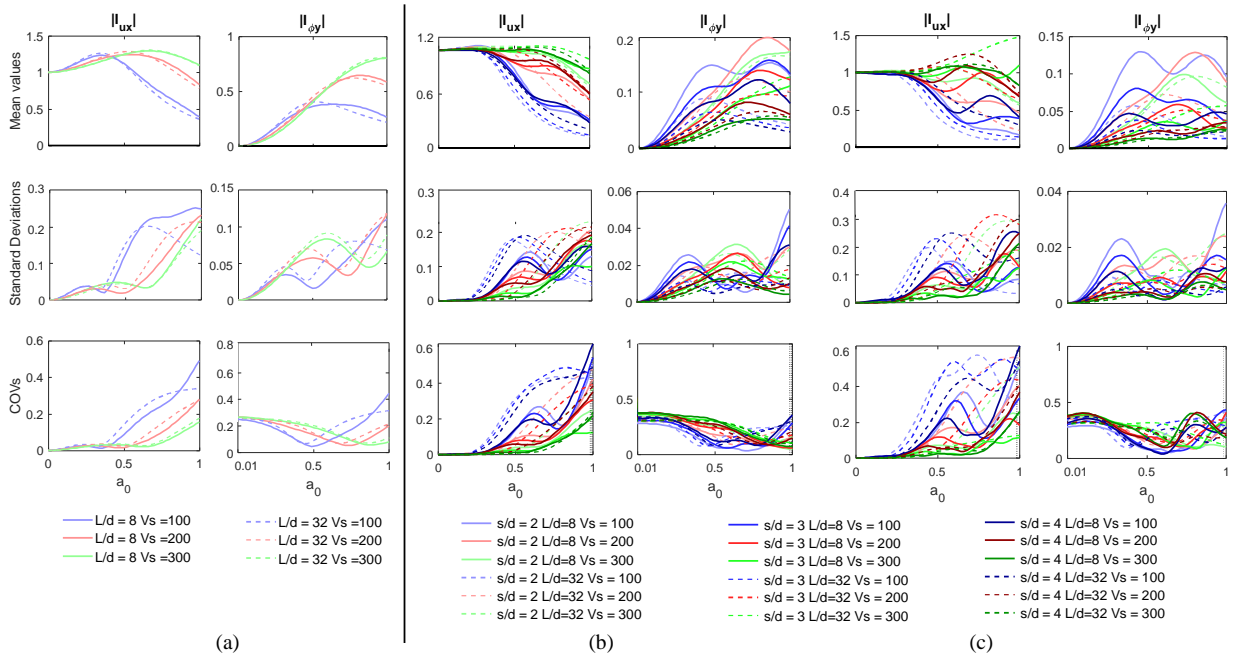

Figure 17. Frequency dependent mean values, standard deviations and COVs of FIM components of (a) single pile foundations, (b) 2x2 and (c) 3x3 pile group foundation

4.2.1. Sensitivity indexes

The first order sensitivity indexes \bar{S}_i for ρ_s , V_s and E_p are presented and discussed in this section. Bar charts in Table 6 collect the sensitivity indexes of all the investigated single piles. For both the kinematic response factors, the V_s is primarily responsible for the global variability of the results as demonstrated by the very high values of the sensitivity indexes (up to 0.95). Uncertainties in the soil density and the pile Young's modulus have a negligible effect on the variability of the kinematic parameters. Bar charts in Table 7 refers to all the investigated pile groups foundations (2x2 and 3x3). Similarly to the single piles, the sensitivity indexes of V_s are very high, especially for the rotational kinematic response factor. In case of pile groups, a slightly higher effect of the soil density uncertainties is evident in the variability of the translational kinematic response factor, as documented by the sensitivity indexes of ρ_s , which for some cases are around 0.15.

Table 6: Sensitivity indexes for single piles' kinematic response factors.

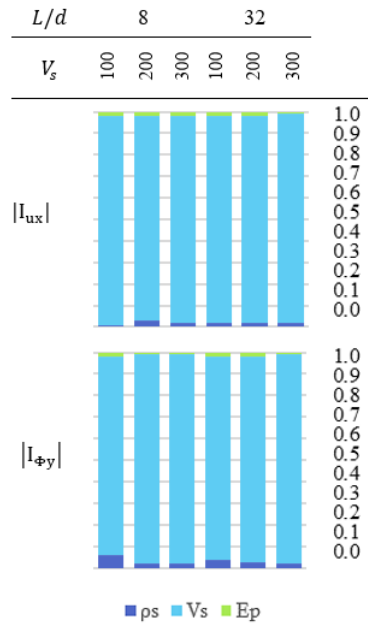
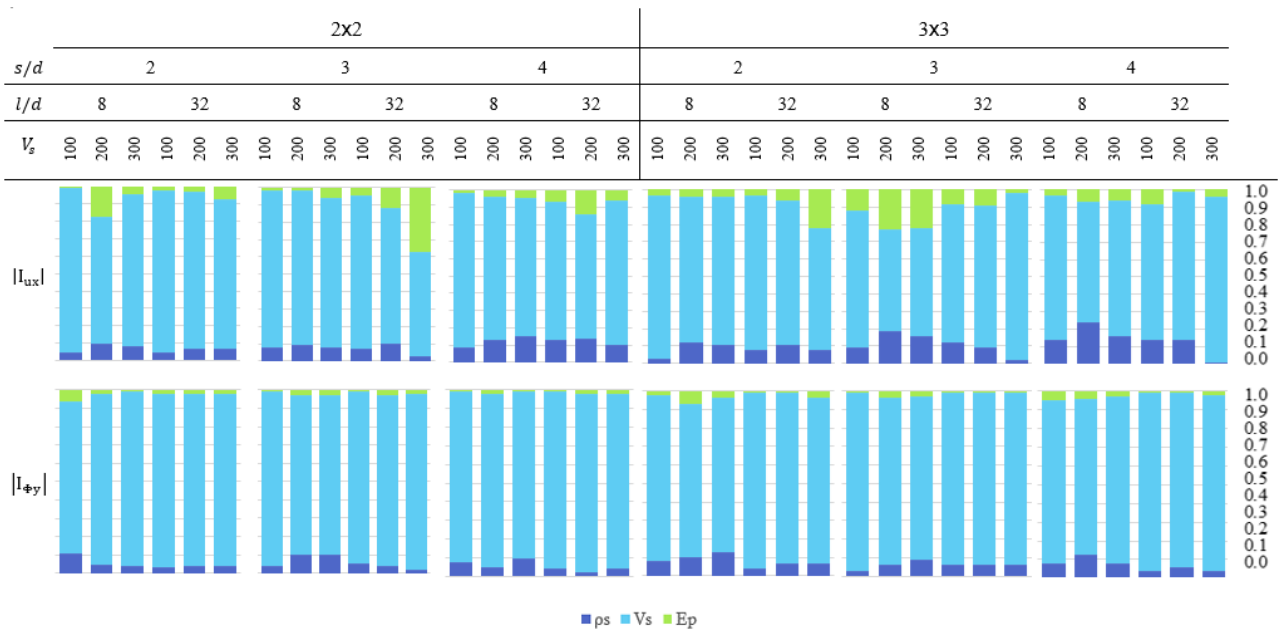

Table 7: Sensitivity indexes for pile group foundations' kinematic response factors.



5 CONCLUSIONS

In this paper a probabilistic investigation on the dynamic behaviour of pile foundations has been presented, with the purpose of addressing effects of intrinsic uncertainties of the main parameters governing the soil-piles interaction problem on the soil-foundation dynamic impedance and kinematic response factors. The soil density, the shear wave velocity and the concrete elastic modulus of piles are assumed as independent random variables and probabilistic distributions available in the literature are adopted to reproduce their uncertainties. A Quasi-Random simulation technique is exploited to generate samples. Floating piles in homogeneous deposits are analysed considering different layouts and statistic parameters of the output quantities, derived from a total of 420000 cases, are presented and discussed.

The following **main findings** can be derived with respect to the variability of the soil-foundation impedances:

- probability distributions of impedances vary sensibly with frequency and, from an overall point of view, the data fitting with a unique known probability density function is not feasible.
- Scattering of results are higher for frequency ranges in which impedances are characterised by high gradients.
- Coefficients of variations highlight peaks for frequency ranges corresponding to the resonance of the soil-foundation system; this phenomenon suggests that impedance uncertainties are important since they may reflect significantly on the response of the superstructure, especially for those characterised by a fundamental period close to the resonance of the soil-foundation system.
- Sensitivity indexes reveal that the shear wave velocity is often mainly responsible for the global variability of the results; however, also uncertainties in the pile elastic modulus and the soil density may affect the results dispersions: as an example, the former is relevant for the rotational impedance of single piles, while the latter affects sensibly the imaginary parts of impedances of pile groups.

The following **main conclusions can be drawn regarding** the variability of the soil-foundation kinematic response factors:

- probability distributions of the parameters vary sensibly with frequency because of their peculiar trends, which makes the selection of a suitable distribution from those available in the literature a non-sense.
- Like for impedances, scattering of results are higher for frequency ranges in which impedances are characterised by high gradients.
- Sensitivity indexes reveal that the shear wave velocity is always the main variable affecting the global variability of the results.

Overall, uncertainties in the soil shear wave velocities are the most important ones and cannot be neglected in the probabilistic modelling of soil-foundation-superstructure **systems**, while uncertainties in the soil density and pile Young's modulus are often less important and may be disregarded in many practical cases. The probabilistic investigation clearly outlines that the variability of the dynamic response of single piles and pile groups is important, especially for higher frequency ranges, where both the frequency-dependent impedances and kinematic response factors are characterised by high gradients. It is worth observing that these phenomena occur at different frequencies depending on the foundation layout but are typical of all pile group foundations, and are almost independent on the model adopted for the analyses. **Thus, although the widening of the foundation layouts is recommended, as well as the inclusion of stratified media, above conclusions may be assumed of general validity.**

DECLARATIONS

Funding: the research is not supported by any funding.

Conflicts of interest: there are no conflict of interests.

Availability of data and material: data are available upon reasonable request from the corresponding author.

Code availability: codes are developed by the authors in Matlab environment [54].

REFERENCES

- [1] Lou M, Wang H, Chen X, Zhai Y. Structure–soil–structure interaction: Literature review. *Soil Dyn Earthq Eng* 2011; 31(12):1724-1731.
- [2] Stewart JP, Fenves GL, Seed RB. Seismic soil–structure-interaction in buildings I: analytical methods. *ASCE J Geotech Geoenviron Eng* 1999; 125(1):26–37.
- [3] Stewart JP, Fenves GL, Seed RB. Seismic soil–structure-interaction in buildings II: empirical findings. *ASCE J Geotech Geoenviron Eng* 1999; 125(1):38-48.

- [4] Aviles J, Pirez-Rocha LE. Soil–structure interaction in yielding systems. *Earthq. Eng. Struct. Dyn.* 2003; 32(11):1749–71.
- [5] Mylonakis G, Nikolaou A, Gazetas G. Soil–pile–bridge seismic interaction: kinematic and inertial effects. Part I: soft soil. *Earthq Eng Struct Dyn* 1997; 26(3):337-359.
- [6] Sextos AG, Pitilakis KD, Kappos AJ. Inelastic dynamic analysis of RC bridges accounting for spatial variability of ground motion, site effects and soil–structure interaction phenomena. Part 1: Methodology and analytical tools. *Earthq Eng Struct Dyn* 2003; 32(4):607-627.
- [7] Carbonari S, Dezi F, Leoni, G. Linear soil–structure interaction of coupled wall–frame structures on pile foundations. *Soil Dyn Earthq Eng* 2011; 31(9):1296-1309.
- [8] Carbonari S, Morici M, Dezi F, Gara F, Leoni G. Soil-structure interaction effects in single bridge piers founded on inclined pile groups. *Soil Dyn Earthq Eng* 2017; 92:52-67.
- [9] Stefanidou SP, Sextos AG, Kotsoglou AN, Lesgidis N, Kappos AJ. Soil-structure interaction effects in analysis of seismic fragility of bridges using an intensity-based ground motion selection procedure. *Eng Struct* 2017; 151:366-80
- [10] Carbonari S, Dezi F, Leoni G. Seismic soil-structure interaction in multi-span bridges: application to a railway bridge. *Earthq Eng Struct Dyn* 2011; 40(11):1219-1239.
- [11] Mylonakis G, Gazetas G. Seismic soil-structure interaction: beneficial or detrimental? *J Earthq Eng* 2000; 4(3):277-301.
- [12] Wolf JP. *Dynamic soil–structure interaction*. New Jersey: Prentice-Hall; 1985.
- [13] Sextos AG, Pitilakis KD, Kappos AJ. Inelastic dynamic analysis of RC bridges accounting for spatial variability of ground motion, site effects and soil- structure interaction phenomena. Part 2: parametric study. *Earthq Eng Struct Dyn* 2003; 32(4):629-652.
- [14] Lutes LD, Sarkani S, Jin S. Response variability of an SSI system with uncertain structural and soil properties. *Eng Struct* 2000; 22(6):605-620.
- [15] Cottureau R, Clouteau D, Soize C. Construction of a probabilistic model for impedance matrices. *Computer Methods in Applied Mechanics and Engineering* 2007; 196(17–20):2252-2268.
- [16] Soize C. A nonparametric model of random uncertainties for reduced matrix models in structural dynamics. *Prob. Engrg. Mech.* 2000;15: 277-294.
- [17] Soize C. Maximum entropy approach for modeling random uncertainties in transient elastodynamics. *J. Acoust. Soc. Am.* 2001;109(5): 1979-1996.
- [18] Moghaddasi M, Cubrinovski M, Chase JG, Pampanin S, Carr A. Probabilistic evaluation of soil-foundation-structure interaction effects on seismic structural response. *Earthq Eng Struct Dyn* 2011; 40(2):135-154.
- [19] Sobol' IM, Turchaninov VI, Levitan YL, Shukhman BV. *Quasirandom sequence generators*. Institute of Applied Mathematics, Russian Academy of Sciences, Moscow; 1992.
- [20] Dezi F, Carbonari S, Leoni G. A model for the 3D kinematic interaction analysis of pile groups in layered soils. *Earthq Eng Struct Dyn* 2009; 38(11):1281-1305.
- [21] Álamo GM, Martínez- Castro AE, Padrón LA, Aznárez JJ, Gallego R, Maeso O. Efficient numerical model for the computation of impedance functions of inclined pile groups in layered soils. *Eng Struct* 2016; 126:379- 390.
- [22] Dezi F, Carbonari S, Morici M. A numerical model for the dynamic analysis of inclined pile groups. *Earthq Eng Struct Dyn* 2015; 45(1):45- 68.
- [23] Padrón LA, Aznárez JJ, Maeso O. BEM–FEM coupling model for the dynamic analysis of piles and pile groups. *Eng Anal Bound Elem* 2007; 31(6):473- 484.
- [24] Dobry R, Gazetas G. Simple method for dynamic stiffness and damping of floating pile groups. *Geotechnique* 1988; 38(4):557- 574.

- [25] Gazetas G, Dobry R. Horizontal response of piles in layered soil. *J Geotech Eng* 1984; 110(1):20- 34.
- [26] Dobry R, Vicente E, O'Rourke MJ, Roesset JM. Horizontal stiffness and damping of single piles. *J Geotech Eng Div ASCE* 1982; 108(GT3):439-59.
- [27] Makris N, Gazetas G. Displacement phase differences in a harmonically oscillating pile. *Geotechnique* 1993; 43(1):135-50.
- [28] Gazetas G, Dobry R. Simple radiation damping model for piles and footings. *J Eng Mech ASCE* 1984; 110(6):937-56.
- [29] Makris N, Gazetas G. Dynamic pile–soil–pile interaction. Part II: lateral and seismic response. *Earthq Eng Struct Dyn* 1992; 21(2):145-162.
- [30] Mylonakis G, Gazetas G. Vertical vibration and additional distress of grouped piles in layered soil. *Soils and Foundations* 1998; 38(1):1-14.
- [31] Capatti MC, Carbonari S, Dezi F, Gara F, Leoni G. Validation of a 3D model for dynamic soil-structure-interaction of pile foundations by means of in situ tests. In *Atti del XVII Convegno ANIDIS L'ingegneria Sismica in Italia: Pistoia, 17-21 settembre 2017*; 68-77.
- [32] Dezi F, Roia D, Capatti MC, Carbonari S, Gara F, Leoni G, Morici M. Evaluation of dynamic soil-pile interaction based on both full scale in situ tests and numerical simulations. In *7th International Conference on Earthquake Geotechnical Engineering (ICEGE) 2019*; CRC Press.
- [33] Phoon KK, Kulhawy FH. Evaluation of geotechnical property variability. *Canadian Geotechnical Journal* 1999; 36(4):625-639.
- [34] Phoon K, Nadim F, Uzielli M, Lacasse S. Soil variability analysis for geotechnical practice. In *Characterisation and Engineering Properties of Natural Soils 2006*; Taylor Francis.
- [35] Mayne PW, Coop MR, Springman S, Huang AB, Zornberg J. State-of-the-Art Paper (SOA-1): GeoMaterial Behavior and Testing. In *Proc. 17th Intl. Conf. Soil Mechanics & Geotechnical Engineering 2009*; 4:2777-2872.
- [36] Bartlett FM, MacGregor JG. Statistical analysis of the compressive strength of concrete in structures. *ACI Mater J* 1996; 93(2):158–68.
- [37] Nielson, BG. Analytical fragility curves for highway bridges in moderate seismic zones. Georgia Institute of Technology; 2005.
- [38] Stefanidou SP, Kappos AJ. (2017). Methodology for the development of bridge- specific fragility curves. *Earthq Eng Struct Dyn* 2017; 46(1):73-93.
- [39] Jones AL, Kramer SL, Arduino P. Estimation of uncertainty in geotechnical properties for performance-based earthquake engineering. Technical Report 2002/16, Pacific Earthquake Engineering Research Center, PEER, Univ. of California at Berkeley, Berkeley, Calif., 2002.
- [40] Moon SW, Ku T. Empirical estimation of soil unit weight and undrained shear strength from shear wave velocity measurements. In *Proceedings, 5th International Conference on Geotechnical and Geophysical Site Characterization (ISC'5)*. Australian Geomechanics Society 2016; 2:1247-1252.
- [41] Griffiths, S. C., Cox, B. R., Rathje, E. M., & Teague, D. P. (2016). Surface-wave dispersion approach for evaluating statistical models that account for shear-wave velocity uncertainty. *Journal of Geotechnical and Geoenvironmental Engineering*, 142(11), 04016061.
- [42] CNR. Guide for the probabilistic assessment of the seismic safety of existing buildings. Report CNR-DT 212/2013, CNR – Advisory Committee on Technical Recommendations for Construction, Rome; 2014.
- [43] EN1992-1-1:2004 Eurocode 2: Design of concrete structures - Part 1-1: General rules and rules for buildings.
- [44] Jin S, Lutes LD, Sarkani S. Response variability for a structure with soil–structure interactions and uncertain soil properties. *Probabilistic Engineering Mechanics* 2000; 15(2):175-183.

- [45] Saltelli A, Tarantola S, Campolongo F, Ratto M. Sensitivity analysis in practice: a guide to assessing scientific models. Chichester, England; 2004.
- [46] Saltelli A, Ratto M, Andres T, Campolongo F, Cariboni J, Gatelli D, Saisana M, Tarantola, S. Global sensitivity analysis: the primer. John Wiley & Sons; 2008.
- [47] Saltelli A, Annoni P, Azzini I, Campolongo F, Ratto M, Tarantola S. Variance based sensitivity analysis of model output. Design and estimator for the total sensitivity index. *Computer Physics Communications* 2010; 181(2):259-270.
- [48] Rubinstein RY, Kroese DP. *Simulation and the Monte Carlo method*. Vol. 10, John Wiley & Sons, 2016.
- [49] Minnucci L, Dezi F, Carbonari S, Morici M, Gara F, Leoni G. Effects of uncertainties of soil and pile mechanical properties on the dynamic stiffness of single piles in homogenous deposits. In 7th International Conference on Computational Methods in Structural Dynamics and Earthquake Engineering (COMPdyn) 2018.
- [50] El-Marsafawi. Dynamic analysis of single piles and pile groups (Doctoral dissertation, University of Western Ontario), November 1993.
- [51] Carbonari S, Morici M, Dezi F, Leoni G. Analytical evaluation of impedances and kinematic response of inclined piles. *Eng Struct* 2016; 117:384-396.
- [52] Kaynia AM. Dynamic stiffness and seismic response of pile groups (Doctoral dissertation, Massachusetts Institute of technology), January 1982.
- [53] Fan K, Gazetas G, Kaynia A, Kausel E, Ahmad S. (1991). Kinematic seismic response of single piles and pile groups. *J Geotech Eng* 1991; 117(12):1860-1879.
- [54] MATLAB 2020b, The MathWorks, Inc., Natick, Massachusetts, United States.

[Click here to view linked References](#)

A Probabilistic Investigation on the Dynamic Behaviour of Pile Foundations in Homogeneous Soils

Minnucci Lucia¹, Morici Michele², Carbonari Sandro^{1*}, Dezi Francesca³, Gara Fabrizio¹, Leoni Graziano²

¹ *Università Politecnica delle Marche - DICEA Via Brecce Bianche, 60131 Ancona, Italy*

² *University of Camerino - SAAD Viale della Rimembranza, 63100, Ascoli Piceno, Italy*

³ *University of San Marino - DESD Via Consiglio dei Sessanta, 99 47891 Dogana – Repubblica di San Marino*

*Corresponding author: s.carbonari@univpm.it

ABSTRACT

Soil-structure interaction is a complex problem to address in structural design due to difficulties related to the modelling of the soil-foundation behaviour, which is frequency-dependent and affected by uncertainties. The substructure method is an efficient approach to include the soil-foundation behaviour in the superstructure response, since it allows addressing separately the soil-foundation and the superstructure analysis exploiting different tools and expertise. A deterministic approach is usually adopted for the soil-foundation system analysis selecting properties of foundation and soil based on an engineering judgment, despite uncertainties due to the intrinsic variability of soil parameters are largely recognised by both scholars and practitioners, as well as confirmed by experimental campaigns and laboratory tests. This paper presents a probabilistic perspective of the dynamic behaviour of pile foundations in homogeneous soils, focusing on the effects of the uncertainties in: (i) the frequency-dependent impedance functions; and (ii) the kinematic response factors necessary to derive the foundation input motion from the free-field motion. Single piles and square pile groups are considered. Uncertainties are described through the probabilistic distributions of parameters governing the soil-foundation dynamic response, while the samples are generated using the quasi-random sampling technique. Probabilistic analyses are performed utilizing an efficient numerical model that has been developed, and the variability of the output quantities is presented and discussed. The latter reveals to vary strongly with frequency. In addition, sensitivity analyses are performed to investigate the influence of each variable uncertainty on the system response. The response quantities are highly sensitive to the shear wave velocity while the soil density and the pile elastic modulus may have a significant role, depending on the foundation layout.

Keywords: Impedance functions, kinematic response factors, Pile foundations, Probabilistic analysis, Quasi random sampling, Sensitivity analysis, Soil-foundation system, Soil-Structure Interaction.

1 INTRODUCTION

Effects of Soil-Structure Interaction (SSI) on the seismic response of structural systems are widely studied in the literature [e.g., 1-4]. It is well recognized that, in case of deep foundations [e.g., 5-11], the interaction between piles and soil can cause detrimental consequences on the superstructure and the response from a fixed-base modelling could not be conservative. In order to properly include the effects of SSI, the substructure method [12] is one of the most common approaches adopted by both scientific community and practitioners due to its ease of application under the simplifying hypothesis of linear (or linear equivalent) behaviour for the soil-foundation sub-system [13]. The approach requires firstly the analysis of the soil-foundation system subjected to unit harmonic displacements, acting on a reference point of the foundation, to obtain the dynamic frequency-dependent impedance matrix. Subsequently, with the same model, the analysis of the soil-foundation system subjected to the propagation of seismic waves in the soil deposit (kinematic interaction) provides the Foundation Input Motion (FIM) (i.e., the displacements experienced by the foundation that actually differ from the free-field motion) and stresses in the foundation piles. The soil-foundation impedances are subsequently used to account for the foundation dynamic compliance in the inertial interaction analysis of

the superstructure subjected to the FIM. This analysis provides stresses in piles that have to be superimposed to the kinematic effects evaluated with the previous kinematic analysis.

Uncertainties in soil-foundation systems are often considered by engineers through an empirical approach based on assuming different extreme values for those parameters deemed to play a key role in the system response, and for which the on site investigation has shown a certain variability. This approach, based on the expert judgment and few analyses, try to treat uncertainties due to the spatial variability of the geological conditions, the limited number of measurements, and the errors of testing and measurement procedures. From a rigorous point of view, probabilistic analyses should be adopted to model uncertainties of parameters affecting the system behaviour and to evaluate the response scattering. With new computational capacities, the probabilistic approach is becoming a common practice in the research, when studying response of prototypal structural systems, or in the practice when analysing strategic structures. However, it is not yet common to adopt a full probabilistic perspective to approach the study of SSI phenomena. Lutes et al. [14] studied effects of soil and superstructure uncertainties on SSI of a shallow foundation, introducing a deterministic variability range on the nominal values of the soil shear stiffness, the soil Poisson's ratio, the superstructure shear stiffness and damping. Cottureau et al. [15] adopted a non-parametric approach [16-17] to construct a probabilistic model for impedance matrices; uncertainties are not defined for the soil-foundation system parameters and then propagated to impedances, but rather taken directly into account in the impedance matrices. Moghaddasi et al. [18] performed Monte Carlo simulations to evaluate the probabilistic seismic response of a single degree of freedom system, considering geometrical and mechanical uncertainties of both the soil-foundation system, represented through a shallow foundation frequency independent lumped parameter model, and the structure, assuming the random variables affecting the response to be uniformly distributed within selected ranges, covering a wide range of practical scenarios. However, to the best of the authors' knowledge, no detailed studies have been yet developed regarding the probabilistic dynamic behaviour of pile foundations, although the variability and uncertainties of the geotechnical properties play an important role in their dynamic response. Hence, the definition of probabilistic models describing the dynamic properties of the soil-foundation system needs further investigations in order to better address the effects of uncertainty relative to the soil and foundations on the superstructure response.

This paper presents the analysis of the dynamic behaviour of pile foundations in a probabilistic framework, in which uncertainties are accounted for through probabilistic distributions of the main parameters governing the soil-foundation dynamic response. Frequency dependent impedance functions of both single piles and square pile groups as well as kinematic response factors are investigated. By assuming uncorrelated probabilistic distributions for the selected random variables, samples are derived using the Quasi-Random Sampling (QRS) technique [19], which allows to obtain a reliable probabilistic distribution of the output quantities with low computational effort. Probabilistic analyses are performed by using a numerical model developed by the authors for the kinematic interaction analysis of single piles and pile groups [20]. The model accounts for the pile-soil-pile interaction, the soil hysteretic and radiation damping, which all affect the dynamic behaviour of deep foundations. The variability of the output quantities is presented and discussed. In addition, sensitivity studies are performed to illustrate the influence of variability of each considered random variable on the system response.

2 SOIL-FOUNDATION MODELLING AND UNCERTAINTIES

2.1 Modelling of the soil-pile foundation interaction

Many different models are available in the literature to evaluate the dynamic stiffness and the kinematic response of pile group foundations [20-25]. Among them, the numerical model proposed by Dezi et al. [20] permits to perform 3D kinematic interaction analyses of vertical and inclined piles, considered as elastic Euler-Bernoulli beam elements embedded in an infinite horizontally layered viscoelastic soil. Soil layers are assumed to be independent and the pile-soil-pile interactions at each layer is described by Green's functions derived in the frequency domain from the dynamics of oscillating rigid disks, accounting for both hysteretic and radiation damping [26-28]. An example of a pile group foundation and the relevant finite element model is depicted in

Figure 1. Because of the problem linearity, the dynamic equilibrium of a vertical pile foundation is expressed by the following complex valued system of linear algebraic equations in the frequency domain

$$\left(\mathbf{K}_p - \omega^2 \mathbf{M}_p + \mathbf{K}_s(\omega) \right) \mathbf{d}(\omega) = \mathbf{f}(\omega) \quad (1)$$

where \mathbf{K}_p and \mathbf{M}_p are the global stiffness and mass matrices of piles, respectively, $\mathbf{K}_s(\omega)$ is the impedance matrix of the soil, $\mathbf{d}(\omega)$ is the piles nodal displacement vector and $\mathbf{f}(\omega)$ is the vector of external loads due to the free-field motion and the pile-soil-pile interaction forces. The impedance matrix of the soil and the vector of external loads are obtained by assembling contributions of all the E elements as

$$\mathbf{K}_s(\omega) = \sum_{e=1}^E \int_0^{L_e} \mathbf{N}^T \mathbf{D}_s^{-1}(\omega, z) \mathbf{N} dz \quad (2a)$$

$$\mathbf{f}(\omega) = \sum_{e=1}^E \int_0^{L_e} \mathbf{N}^T \mathbf{D}_s^{-1}(\omega, z) \mathbf{u}_{ff} dz \quad (2b)$$

where L_e is the finite element length, \mathbf{N} is the matrix of the interpolating polynomials, \mathbf{u}_{ff} is the vector collecting the free-field motion components in the x , y and z directions (Figure 1b) while $\mathbf{D}_s(\omega, z)$ is the local soil-pile compliance matrix assembled considering Green's functions available in the literature [20].

The pile cap is modelled with a rigid body constraint applied to pile head nodes; the constraint Master node (M) has 6 degrees of freedom and is positioned at the centroid of the pile group at the level of the pile heads. By denoting the geometric matrix of the kinematic constraint by \mathbf{A} , Equation (1) assumes the form

$$\tilde{\mathbf{K}}(\omega) \tilde{\mathbf{d}}(\omega) = \tilde{\mathbf{f}}(\omega) \quad (3)$$

where

$$\tilde{\mathbf{K}}(\omega) = \mathbf{A}^T \left(\mathbf{K}_p - \omega^2 \mathbf{M}_p + \mathbf{K}_s(\omega) \right) \mathbf{A} \quad (4a)$$

$$\tilde{\mathbf{f}}(\omega) = \mathbf{A}^T \mathbf{f}(\omega) \quad (4b)$$

In Equation (3), $\tilde{\mathbf{d}}(\omega)$ is the vector collecting the six displacement components of M and the displacement components of the remaining non-constrained pile nodes. Equation (3) can be partitioned as follows to separate displacements of the master node (\mathbf{U}_M) from those of the embedded pile nodes (\mathbf{d}_S):

$$\begin{pmatrix} \tilde{\mathbf{K}}_{MM} & \tilde{\mathbf{K}}_{MS} \\ \tilde{\mathbf{K}}_{SM} & \tilde{\mathbf{K}}_{SS} \end{pmatrix} \begin{pmatrix} \mathbf{U}_M \\ \mathbf{d}_S \end{pmatrix} = \begin{pmatrix} \tilde{\mathbf{f}}_M \\ \tilde{\mathbf{f}}_S \end{pmatrix} \quad (5)$$

By condensing system (5) on the master node *dofs*, the following expressions for the complex impedance matrix (\mathfrak{Z}) and the complex FIM (\mathbf{U}_M) can be derived:

$$\mathfrak{Z}(\omega) = \left(\tilde{\mathbf{K}}_{MM} - \tilde{\mathbf{K}}_{MS} \tilde{\mathbf{K}}_{SS}^{-1} \tilde{\mathbf{K}}_{SM} \right) \quad (6a)$$

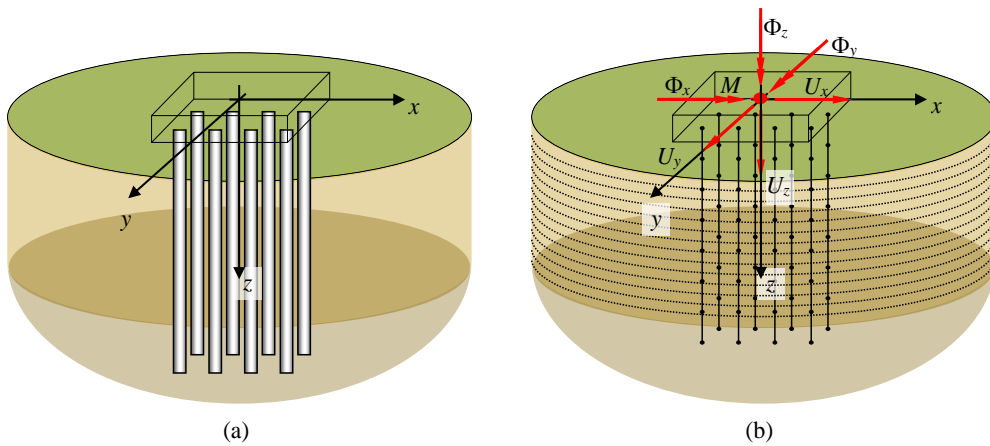

Figure 1. (a) Soil-foundation system; (b) FEM model.

$$\mathbf{U}_M(\omega) = \mathfrak{Z}^{-1}(\tilde{\mathbf{f}}_M - \tilde{\mathbf{K}}_{MS} \tilde{\mathbf{K}}_{SS}^{-1} \tilde{\mathbf{f}}_S) \quad (6b)$$

In case of double-symmetric pile configurations the impedance matrix has the form

$$\mathfrak{Z}(\omega) = \begin{bmatrix} \mathfrak{Z}_x & 0 & 0 & 0 & \mathfrak{Z}_{x-ry} & 0 \\ & \mathfrak{Z}_y & 0 & \mathfrak{Z}_{y-rx} & 0 & 0 \\ & & \mathfrak{Z}_z & 0 & 0 & 0 \\ & & & \mathfrak{Z}_{rx} & 0 & 0 \\ sym & & & & \mathfrak{Z}_{ry} & 0 \\ & & & & & \mathfrak{Z}_{rz} \end{bmatrix} \quad (7)$$

With reference to Figure 1b, $\mathfrak{Z}_x, \mathfrak{Z}_y, \mathfrak{Z}_z$ are the translational frequency dependent impedances along x, y and z , respectively, whereas $\mathfrak{Z}_{rx}, \mathfrak{Z}_{ry}, \mathfrak{Z}_{rz}$ are the rotational impedance components and $\mathfrak{Z}_{x-ry}, \mathfrak{Z}_{y-rx}$ are the coupled roto-translational terms.

Soil and pile material properties and geometric parameters are involved in the definition of the impedance matrix. The pile stiffness and mass matrices overall depend on the elastic modulus of the pile material, the pile diameter, and the pile length. The pile-soil-pile interaction, affecting the global dynamic stiffness matrix of the soil-foundation system and the external loads (Equation (2)), is captured by the soil compliance matrix $\mathbf{D}_s(\omega, z)$ that assumes the form

$$\mathbf{D}_s(\omega, z) = \begin{bmatrix} \mathbf{D}_{11} & \cdots & \mathbf{D}_{1q} & \cdots & \mathbf{D}_{1n} \\ \vdots & & \vdots & & \vdots \\ \mathbf{D}_{p1} & \cdots & \mathbf{D}_{pq} & \cdots & \mathbf{D}_{pn} \\ \vdots & & \vdots & & \vdots \\ \mathbf{D}_{n1} & \cdots & \mathbf{D}_{nq} & \cdots & \mathbf{D}_{nn} \end{bmatrix} \quad (8)$$

Sub-matrices $\mathbf{D}_{pq}(\omega, z)$ appearing in Equation (8) contain the elastodynamic Green's functions expressing the soil displacements at the location of the p -th pile at depth z , due to a time-harmonic unit point load acting at the location of the q -th pile at the same depth. They are expressed as

$$\mathbf{D}_{pq}(\omega, z) = \mathbf{G}_{pq}^T(z) \boldsymbol{\Psi}_{pq}(\omega, z) \mathbf{G}_{pq}(z) \mathfrak{D}(\omega, z) \quad (9)$$

where

$$\mathfrak{D}(\omega, z) = \begin{bmatrix} \frac{k_{\square}(\omega) - i\omega c_{\square}(\omega)}{k_{\square}^2(\omega) + \omega^2 c_{\square}^2(\omega)} & 0 & 0 \\ 0 & \frac{k_{\square}(\omega) - i\omega c_{\square}(\omega)}{k_{\square}^2(\omega) + \omega^2 c_{\square}^2(\omega)} & 0 \\ 0 & 0 & \frac{k_v(\omega) - i\omega c_v(\omega)}{k_v^2(\omega) + \omega^2 c_v^2(\omega)} \end{bmatrix} \quad (10)$$

collects soil displacements at the position of the applied force and matrix $\mathbf{G}_{pq}^T \boldsymbol{\Psi}_{pq} \mathbf{G}_{pq}$ describes the displacement attenuation from point q to point p within each layer [29-30]. Terms appearing in Equation (10) are formulated as follows [26-28]:

$$k_h = 1.67 E_s \left(\frac{E_p}{E_s} \right)^{-0.053} \quad (11a)$$

$$c_h(\omega) = \frac{1}{2} \pi d \rho_s V_s \left[\text{Re} \left(-i \frac{H_1^{(2)} \frac{\pi \omega d}{8V_s}}{H_0^{(2)} \frac{\pi \omega d}{8V_s}} \right) + \frac{V_c}{V_s} \text{Re} \left(-i \frac{H_1^{(2)} \frac{\pi \omega d}{8V_c}}{H_0^{(2)} \frac{\pi \omega d}{8V_c}} \right) \right] + 2\xi_s \frac{k_h}{\omega} \quad (11b)$$

$$k_v(\omega) = 0.6 E_s \left(1 + \frac{1}{2} \sqrt{\frac{\omega d}{V_s}} \right) \quad (11c)$$

$$c_v(\omega) = \pi d \rho_s V_s \left[\operatorname{Re} \left(-i \frac{H_1^{(2)} \frac{\pi \omega d}{8 V_s}}{H_0^{(2)} \frac{\pi \omega d}{8 V_s}} \right) \right] + 2 \xi_s \frac{k_v}{\omega} \quad (11d)$$

where E_p and E_s are the pile material and soil Young's modulus, respectively, while ξ_s is the hysteretic damping ratio of the soil. Furthermore, V_c is the velocity of the compression–extension waves, which can be expressed as a function of the shear wave velocity (Lysmer's analogue velocity), d is the pile diameter and $H_0^{(2)}$ and $H_1^{(2)}$ are the zero-order and first-order Hankel functions of second kind.

2.2 Probabilistic model

The research focuses on aleatoric uncertainties of mechanical parameters affecting the dynamic response of the soil-pile system. Epistemic uncertainties related to modelling are not investigated; however, limits of the adopted numerical model can be retrieved by referring to [20, 31-32] in which comparisons with results obtained from more refined modelling approaches and with available data from experimental tests are discussed.

The inherent variability of mechanical parameters gives rise to aleatoric uncertainties that can be characterized by statistical models and probabilistic laws. Several works from the geotechnical literature deal with the characterization of soil properties based on field tests, resulting in the definition of probabilistic trends for the density, the degree of saturation, the cohesion, the friction angle and many other features [33-35]. Concerning piles, variability of the parameters can be closely associated with the uncertainties on construction material properties. In particular, the use of concrete involves the adoption of probabilistic models regarding the compressive strength, density, and the elastic modulus, which are widely adopted in the literature [36-38]. Less important uncertainties usually characterise steel reinforcements whose behaviour is thus considered to be deterministic in this study. Since pile-soil-pile interaction phenomena are strongly affected by geotechnical parameters, which are sources of uncertainty, a probabilistic approach for the assessment of the soil-foundation system dynamic behaviour is necessary. Considering Equations (11), the soil density ρ_s , the shear wave velocity V_s and the concrete elastic modulus E_p are assumed as independent random variables. Probabilistic models assumed for above variables are deduced from the available technical literature. In particular:

- a normal distribution is considered for the soil density [39];
- a lognormal distribution is considered for the shear wave velocity [40-41];
- a lognormal distribution is considered for the cylindrical compressive concrete strength f_c [42] from which the elastic Young's modulus of the material is derived from [43]

$$E_p = 22000 \left(\frac{f_c + 8}{10} \right)^{0.3} \quad (12)$$

The remaining mechanical parameters, namely soil and concrete Poisson's ratios (ν_s, ν_p), soil and concrete damping ratios (ξ_s, ξ_p) and concrete density ρ_p , are assumed to be deterministic since their variability on the overall dynamic response of the foundation is limited under the assumption of linear soil behaviour [15, 44]. In fact, it is worth observing that most of the damping capacity of the soil-foundation system is attributable to radiation phenomena that are provided by the first addenda of Equations (11b) and (11d) as a function of the above defined random variables. For the purposes of this paper, by limiting furtherly the analysis to square pile groups, the problem previously stated can be turned in a non-dimensional form so that the impedance matrix in Equation (7) can be rewritten as

$$\mathbf{\Pi}(\rho_s, V_s, E_p; a_0) = \begin{bmatrix} \Pi_1 & 0 & 0 & 0 & \Pi_3 & 0 \\ & \Pi_1 & 0 & -\Pi_3 & 0 & 0 \\ & & \Pi_4 & 0 & 0 & 0 \\ & & & \Pi_2 & 0 & 0 \\ sym & & & & \Pi_2 & 0 \\ & & & & & \Pi_5 \end{bmatrix} \quad (13)$$

where ρ_s , V_s and E_p are parameters that are considered subjected to uncertainties,

$$a_0 = \frac{\omega d}{\mu_{V_s}} \quad (14)$$

is the non-dimensional frequency and

$$\Pi_1(\rho_s, V_s, E_p; a_0) = \frac{\Im_i}{\rho_s \mu_{V_s}^2 d} \quad \text{for } i = x, y \quad (15a)$$

$$\Pi_2(\rho_s, V_s, E_p; a_0) = \frac{\Im_{ri}}{\rho_s \mu_{V_s}^2 d^3} \quad \text{for } i = x, y \quad (15b)$$

$$\Pi_3(\rho_s, V_s, E_p; a_0) = \frac{\Im_{i-rj}}{\rho_s \mu_{V_s}^2 d^2} \quad \text{for } i = x, y \text{ and } j = y, x \quad (15c)$$

$$\Pi_4(\rho_s, V_s, E_p; a_0) = \frac{\Im_z}{\rho_s \mu_{V_s}^2 d} \quad (15d)$$

$$\Pi_5(\rho_s, V_s, E_p; a_0) = \frac{\Im_{rz}}{\rho_s \mu_{V_s}^2 d^3} \quad (15e)$$

In addition to the previous relationships relevant to the foundation dynamic compliance, transfer functions between the free field motion and the FIM can be considered to be representative for the foundation kinematic response. These are represented by ratios between FIM components and free field motion at the soil outcrop. By considering the earthquake shaking to be constituted by vertically travelling shear waves, because of the square layout of pile groups considered, the following transfer functions can be defined:

$$I_U(\rho_s, V_s, E_p; a_0) = \frac{U_i}{U_{ff,i}} \quad I_\Phi(\rho_s, V_s, E_p; a_0) = \frac{\Phi_i d}{U_{ff,i}} \quad \text{for } i = x, y \quad (16a, b)$$

where $U_{ff,x}$ and $U_{ff,y}$ are the free field displacements at the soil outcrop, and U_x, U_y, Φ_y and Φ_x are the translational and rotational non-null displacement components of the foundation Master node (M), respectively (Figure1b). Once suitable statistical distributions are adopted for the random variables ρ_s, V_s and E_p , Equations (15) and (16) will return impedances and transfer functions with their own distributions that are investigated in this paper.

2.3 Sensitivity index

Impedances Π_j ($j = 1, \dots, 5$) and kinematic transfer functions I_α , ($\alpha = U, \phi$), derived in the previous section, depend on the three independent aleatoric variables ρ_s, V_s and E_p , each characterised by a specific probability distribution. By denoting by Y the generic function and by X_k ($k = 1, \dots, 3$) the aleatoric variables, the following expression:

$$Y = g(X_1, X_2, X_3; a_0) \quad (17)$$

generically represents one of equations (15) and (16). To measure how uncertainties of the generic variable affect uncertainties of the model, the following sensitivity indexes can be considered

$$S_k(a_0) = \frac{V_{X_k}(E_{X \sim k}(Y|X_k))}{V(Y)} \quad (18)$$

where $V_{X_k}(E_{X \sim k}(Y|X_k))$ is the conditional variance of Y , and $V(Y)$ is the total variance. S_k is the first order sensitivity index of X_k [45] varying between 0 and 1; the higher the index, the higher the importance of the variable. As the considered variables are independent, the following relationship holds:

$$\sum_k S_k(a_0) = 1 \quad (19)$$

It is worth noticing that the adopted sensitivity indexes vary within the nondimensional frequency (a_0) range. In an attempt to measure the overall importance of the variable parameter over the frequency range $0 - A_0$ considered, the following mean value can be defined:

$$\bar{S}_k = \frac{1}{A_0} \int_0^{A_0} S_k(a_0) da_0 \quad (20)$$

which is also varying between 0 and 1 and satisfy condition analogous to Equation (19).

3 INVESTIGATED FOUNDATION SYSTEMS

Floating vertical piles embedded in a homogeneous soil deposit are considered; geometric parameters of foundations are assumed to be deterministic. Single piles, 2x2 and 3x3 square pile groups (Figure 2) are investigated. Two pile slenderness ratios L/d (representative of realistic short and long piles), and three pile spacing-diameter ratios s/d (consistently with realistic engineering applications) are considered for a total of 14 geometric models.

As discussed in section 2.2, soil density, shear wave velocity and concrete modulus of elasticity are considered to be aleatoric while the other mechanical parameters, necessary to define the model, are considered to be deterministic. Table 1 reports parameters (mean values and standard deviations) of the probability distributions adopted for the aleatoric parameters. In addition, Table 2 lists the deterministic values adopted for the other parameters.

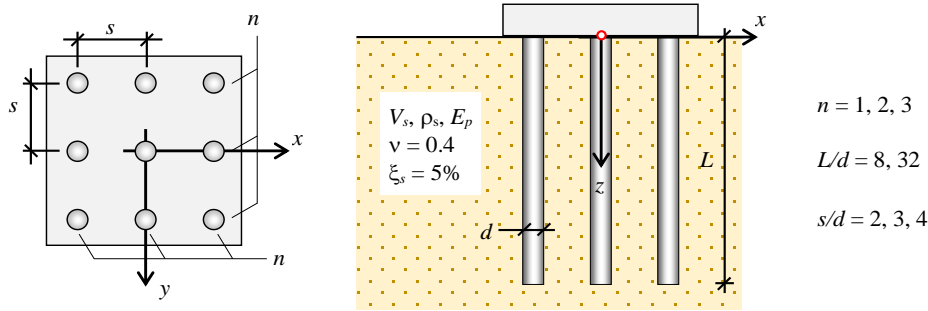

Figure 2. Scheme of investigated soil-foundation systems.

Table 1: Statistical distributions for ρ_s , V_s , E_c .

Uncertainties	Probabilistic Distribution	μ	σ
Soil density ρ_s [t/m ³]	Normal	1.75	$\sigma = 0.175$
Shear wave velocity V_s [m/s]	Lognormal	100, 200, 300	$\sigma_{ln} = 0.10$
Concrete cylindric strength [MPa]	Lognormal	20.12	$\sigma_{ln} = 0.20$

Table 2: Deterministic parameters.

Mechanical parameters	value
Soil Poisson's ratio ν_s [-]	0.40
Soil damping ξ_s [-]	0.05
Pile material Poisson's ratio (concrete) ν_p [-]	0.20
Pile material density (concrete) ρ_p [t/m ³]	2.50

3.1 Generation of samples

The Quasi-Random Sampling (QRS) technique, based on Sobol' Low Discrepancy Sequences (LDSs) [45-47], is adopted in this paper to generate samples that are not random, in the sense of completely unpredictable, but are generated progressively ensuring the selection of new points suitably kept away from previous selected ones. This approach allows reducing the generation of clusters (i.e. overlapping of samples) or gaps (i.e. empty spaces among samples) in the sample domain, assuring the minimum discrepancy, that is to place sample points as uniformly as possible in the variability domain.

The approach consists of the following main steps:

1. the QRS is used to generate two matrixes (A, B) each one collecting s triplets of the selected random variables (ρ_s, V_s, E_p);
2. three further matrixes C_k ($k = 1,2,3$) are generated by in turn replacing one column of A into the corresponding column of B (thus, $s \times 5$ triples constitute the sample domain).

Figure 3 presents the comparison between the classical Monte Carlo Simulation (MCS) sampling [48] and the QRS; Figure 3a shows that, in case of small sample sizes, MCS may generate important clusters or gaps (as can be observed from the 2D section of the sampling domain). On the contrary, the Sobol's LDS allows to obtain a good sample distribution in terms of discrepancy even for rather small numbers of simulations (Figure 3b). The efficiency of the QRS on the independent variables defined in the previous section was proven by the authors in [49] where the QRS is adopted to simulate the parameters variability for a single-pile foundation system. The probabilistic analysis is performed using triplets from A, B and C_i , and the results for each response quantity Y are collected in the corresponding 5 output vectors (of dimension s) for each frequency ($Y_A(a_0), Y_B(a_0), Y_{C_i}(a_0)$). Thanks to this partition of the output, instead of equation (18), the following formula can be adopted to compute the first order sensitivity index [46]:

$$S_k(a_0) = \frac{Y_A(a_0) \cdot Y_{C_k}(a_0) - f_0^2(a_0)}{Y_A(a_0) \cdot Y_A(a_0) - f_0^2(a_0)} \quad (21)$$

in which

$$f_0^2(a_0) = \left(\frac{1}{s} \sum_{i=1}^s Y_{A,i}(a_0) \right)^2 \quad (22)$$

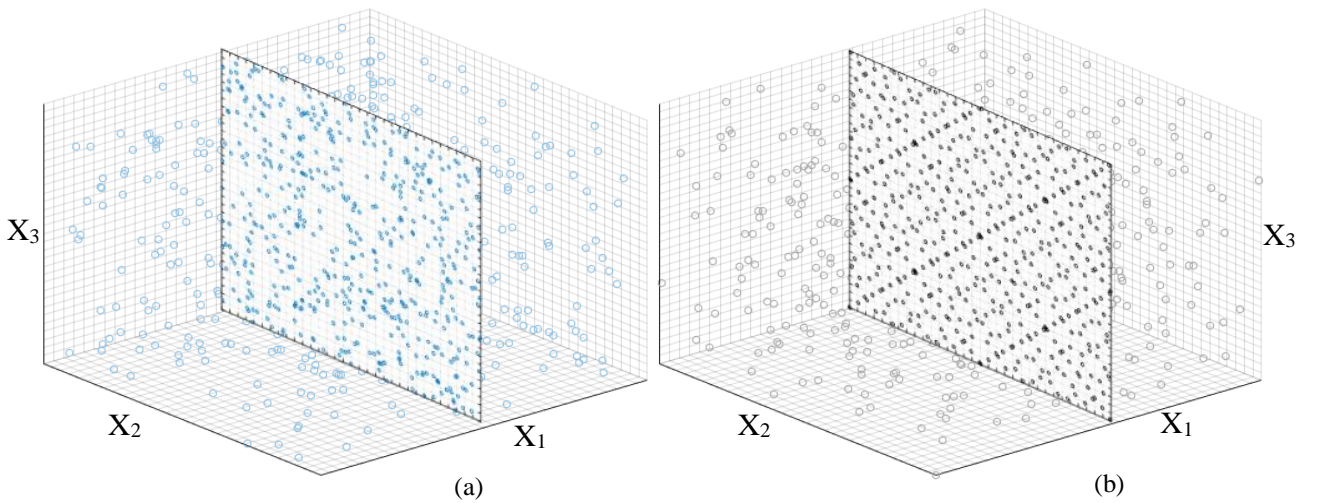

Figure 3. Comparison of samplings obtained with (a) MCS and (b) QRS Sobol' Sequence for 3 uniformly distributed random variables

The sample must be such that condition (19) is satisfied. In this work, $s = 2000$ is assumed, producing a sample of $N = 10.000$ elements. The parameter distributions obtained through the Sobol' QRS are shown in Figure 4 for the investigated random variables; in the same figure, the distributions relevant to a MCS are shown considering the same number of samples, demonstrating the potentials of the former approach to better fit the selected density functions.

4 RESULTS OF PROBABILISTIC SOIL-FOUNDATION DYNAMIC ANALYSES

In this section, results of the probabilistic soil-foundation dynamic analyses performed through the numerical model by Dezi et al. [20] are presented, focusing on the foundation impedance functions and the kinematic response factors. The latter provide a measure of the filtering effect induced by the deep foundation on the free-field motion and can be used to compute the FIM (Equation (6b)). Impedance functions and kinematic response factors are evaluated in the non-dimensional frequency range 0-1, which assures that the frequency range of practical interest (0-10 Hz) in the field of seismic engineering is included. As already mentioned, 10.000 samples are generated for each foundation layout and dynamic analyses are performed for an overall number of 420.000 simulations. As a result, probabilistic distributions of output quantities can be outlined, highlighting the variability of the impedance functions and the kinematic response factors for each foundation layout.

4.1 Variability of impedances

Given the circular frequency, discrete probability density curves are obtained by dividing the range of variability in a number of classes; the class density value is evaluated by dividing the number of realizations of the dataset falling in the class by the total number of samples (relative frequency) and by the width of the class. For the sake of brevity, the probability density functions of impedances are shown in this section for some foundation layouts discussing peculiar trends of results. A complete overview will be presented later focusing on the first two statistical moments. Unless otherwise specified, comments below can be considered of general validity and apply to all the investigated foundations.

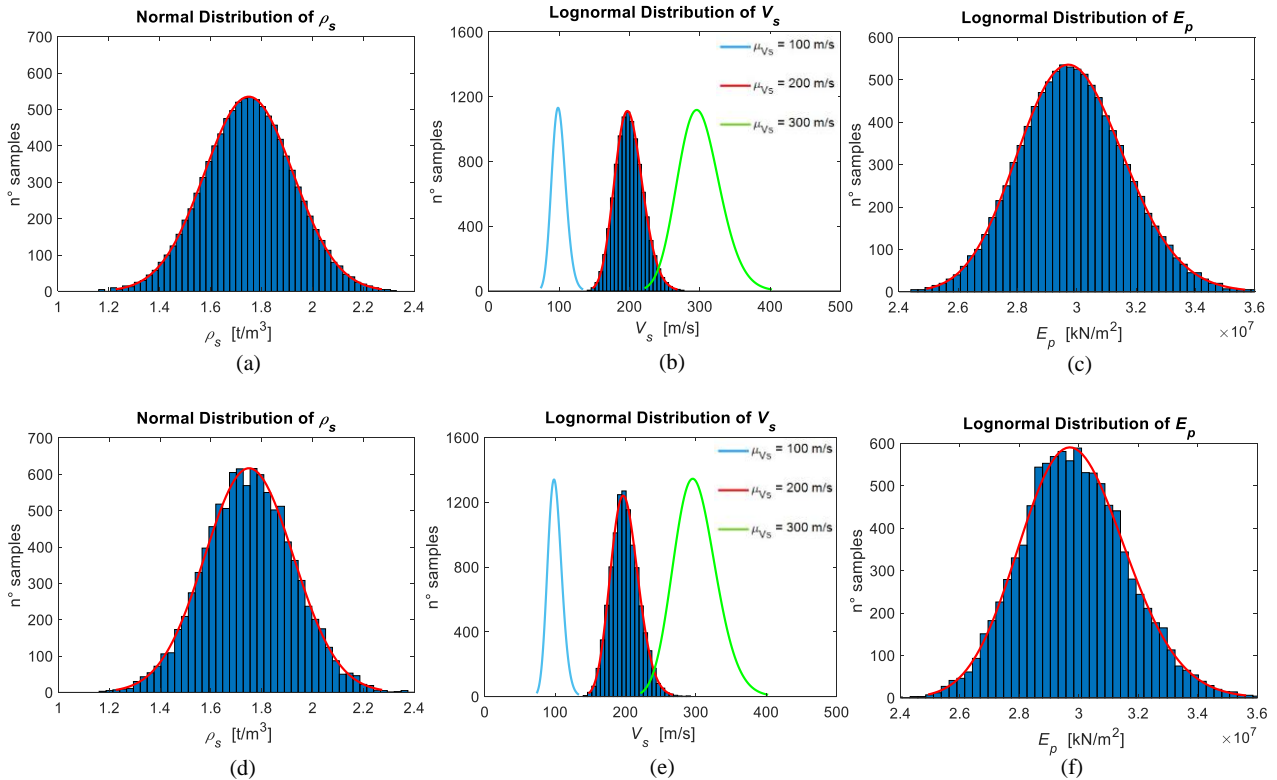

Figure 4. Sample distributions for the random variables: (a) ρ_s , (b) V_s and (c) E_p with Quasi Random technique; (d) ρ_s , (e) V_s and (f) E_p with Monte Carlo simulation.

Figure 5 shows the variability of the real and imaginary parts of the non-dimensional translation impedance Π_1 of the 2x2 foundation for $s/d = 4$, $L/d = 32$ and $V_s = 300$ m/s. In detail, Figure 5a shows a planar view of the frequency-dependent impedance function realizations. Plots represent the probability density by means of a colour scale (bright colours correspond to higher density values). In the same graph three significant quantities are highlighted to characterize the distribution in a probabilistic perspective: the red solid line fits the mean value of impedances, the red dashed curve is the median value and the dotted curve is the mode; furthermore 25th and 75th percentiles are reported. Figure 5b shows curves representing the density distribution of impedances for selected a_0 values (0, 0.25, 0.50, 0.75 and 1.00). Regarding real parts, it is worth observing that the data scattering, which is overall important, varies sensibly with frequency and presents a remarkable reduction in the 0.6-0.8 a_0 range. The mean and median curves are almost coincident within the investigated frequency range, while the mode curve differs sensibly from these at the higher frequencies. It is worth mentioning that data at 0 frequency provides the static stiffness of the soil-foundation system. Concerning imaginary parts, a trend can be recognised for the data dispersions: an overall increase of the scattering is observed by increasing the frequency.

Figure 6 presents the analysis outcomes of the vertical non-dimensional impedance Π_4 of the 3x3 foundation for $s/d = 3$, $L/d = 8$ and $V_s = 200$ m/s. For non-dimensional frequencies a_0 lower than 0.5 the data scattering is not significant; scattering increases repentantly at higher frequencies, especially for the imaginary parts for frequencies higher than 0.75, as clearly depicted in Figure 6b. Considerations about the mean value, the median and the mode of the previous case hold: the mean value practically coincides with both the median and the mode values up to $a_0 = 0.5$ for both the real and imaginary parts of the impedance component.

Similarly, Figure 7 refers to real and imaginary parts of rotational non-dimensional impedance Π_2 for the 2x2 foundation with $s/d = 2$, $L/d = 8$ and $V_s = 100$ m/s. Concerning trends of data scattering, the variability of real part reveals to be almost constant, holding a lognormal-like trend on the transverse probability distributions, while scattering of imaginary parts progressively increase with frequency.

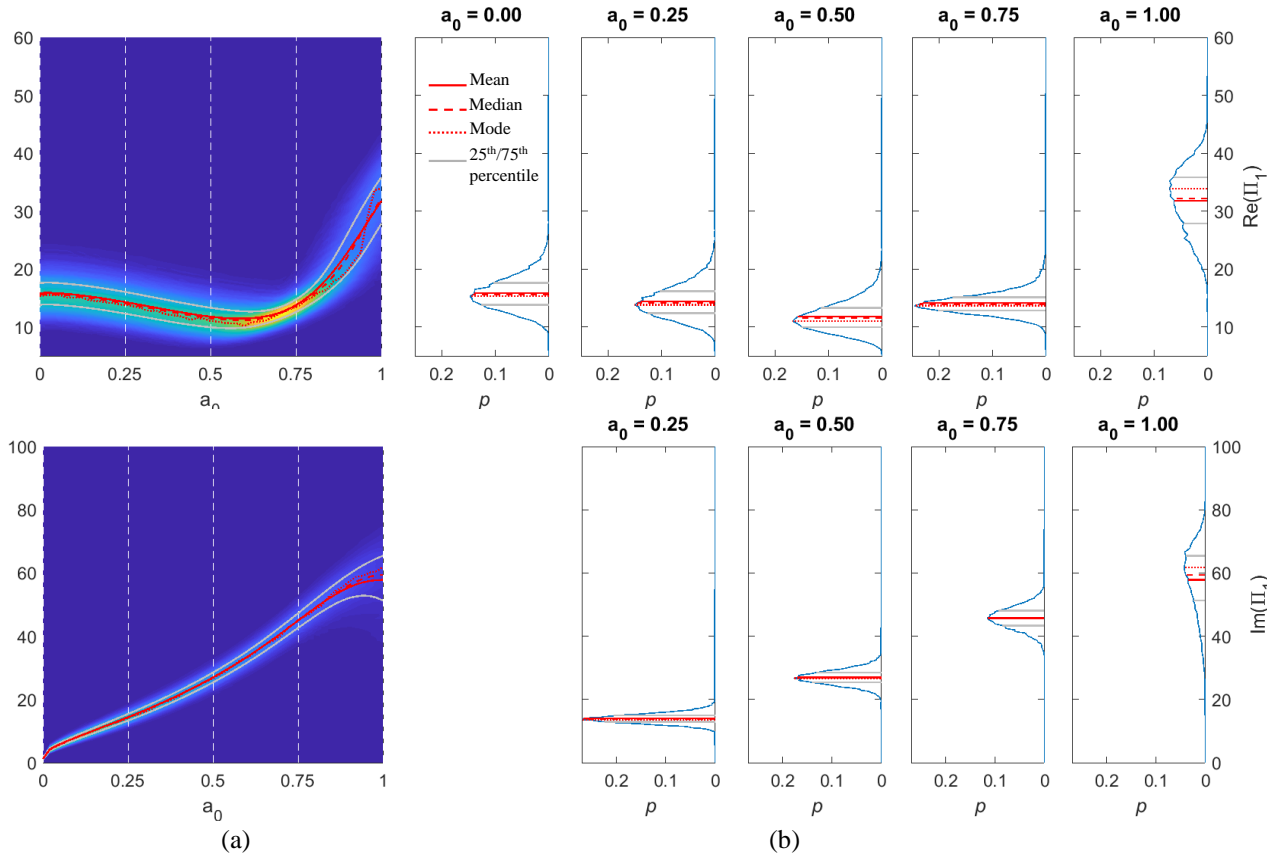

Figure 5. (a) Variability of Π_1 (real and imaginary parts) and (b) distributions of values at selected frequencies
Case 2X2, $s/d = 4$, $L/d = 32$, $V_s = 300$ m/s

From a qualitative point of view, previous considerations concerning the mean, mode and median values hold even if in this case, less important differences among them are obtained in the whole investigated frequency range.

Finally, Figure 8 shows the coupled non-dimensional roto-translational impedance Π_3 of the 3x3 foundation with $s/d = 4$, $L/d = 32$ and $V_s = 200$ m/s. As well known, the typical coupled behaviour of deep foundations stems from the equilibrium of kinematic bending moments at the pile heads, which are due to translations and are equilibrated by axial forces in piles; thus, variability of the coupled roto-translational impedance reflects those of translational and vertical ones. In this sense, similarities in the data scattering with respect to translational (Figure 5) and vertical (Figure 6) impedances are evident although the latter refer to different case studies. Results previously discussed can lead to a general observation: scattering of impedances are very important in the range of frequencies in which impedances are characterised by higher gradients. This is due to the fact that a variation of the aleatoric parameter produces a frequency shift of the impedance functions peaks.

A complete overview of results from case studies relevant to the single piles, the 2x2 and 3x3 pile groups is shown in the sequel in terms of the first two statistical moments (mean values, standard deviations) and the relevant Coefficient Of Variation (COV). Figure 9 refers to impedance functions of the investigated single piles. Comments on the effects of the L/d ratio and V_s are omitted since these are quite well known in the literature [e.g., 50, 51]. On the contrary, some comments about trends of standard deviations and COVs are provided. Standard deviations of all the impedance components present trends that reflect those of the mean values for both the real and imaginary parts. Thus, COVs are almost independent on the case study and are constant with frequency for both the real and imaginary parts of translational, vertical and coupled roto-translational impedances. Overall, real parts have higher COVs than imaginary parts with values of about 25%, 15% and 10% for the translational, coupled roto-translational and vertical impedances, respectively. COVs of the rotational impedance present different trends: higher values are obtained for short piles than for long ones and increase up to 40% by reducing the soil dynamic properties.

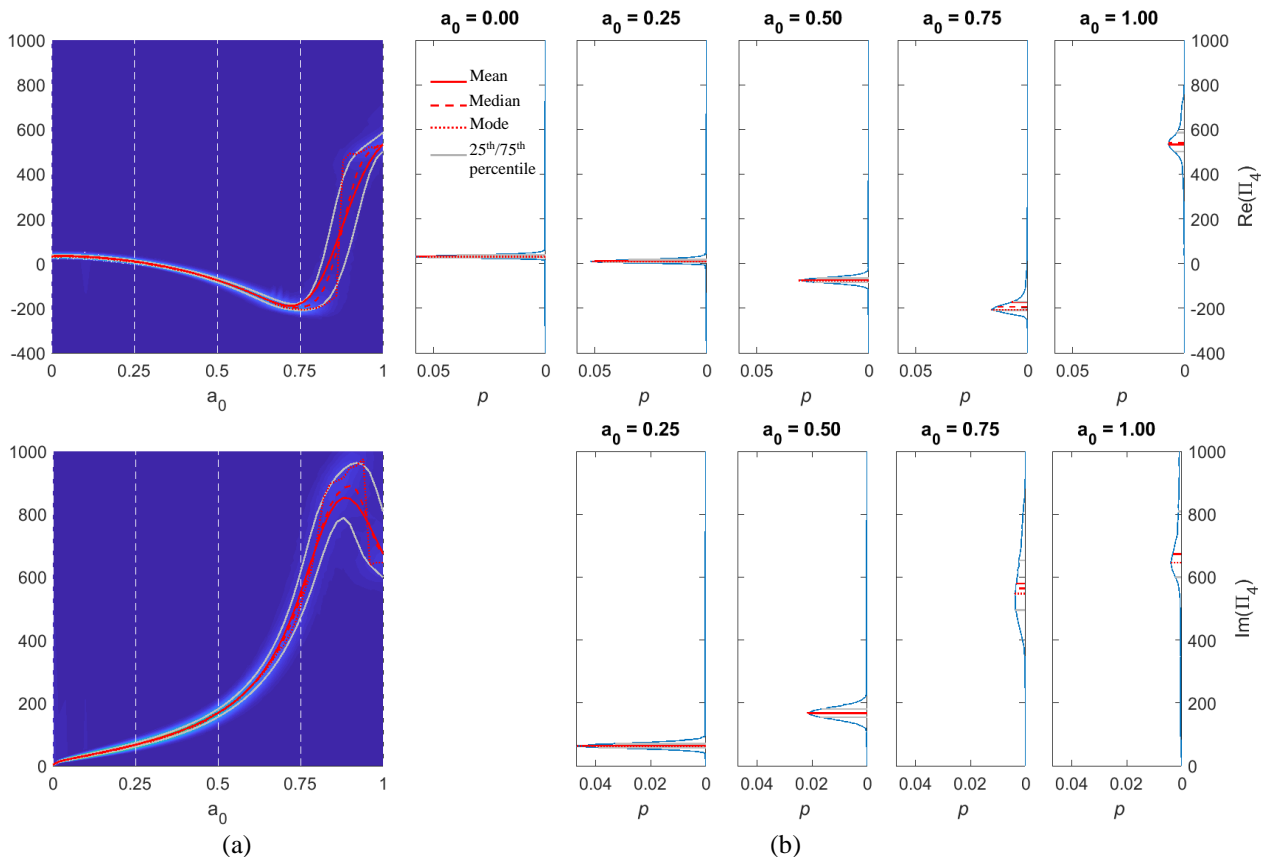

Figure 6. (a) Variability of Π_4 (real and imaginary parts) and (b) distributions of values at selected frequency values
Case 3x3, $s/d = 3$, $L/d = 8$, $V_s = 200$ m/s

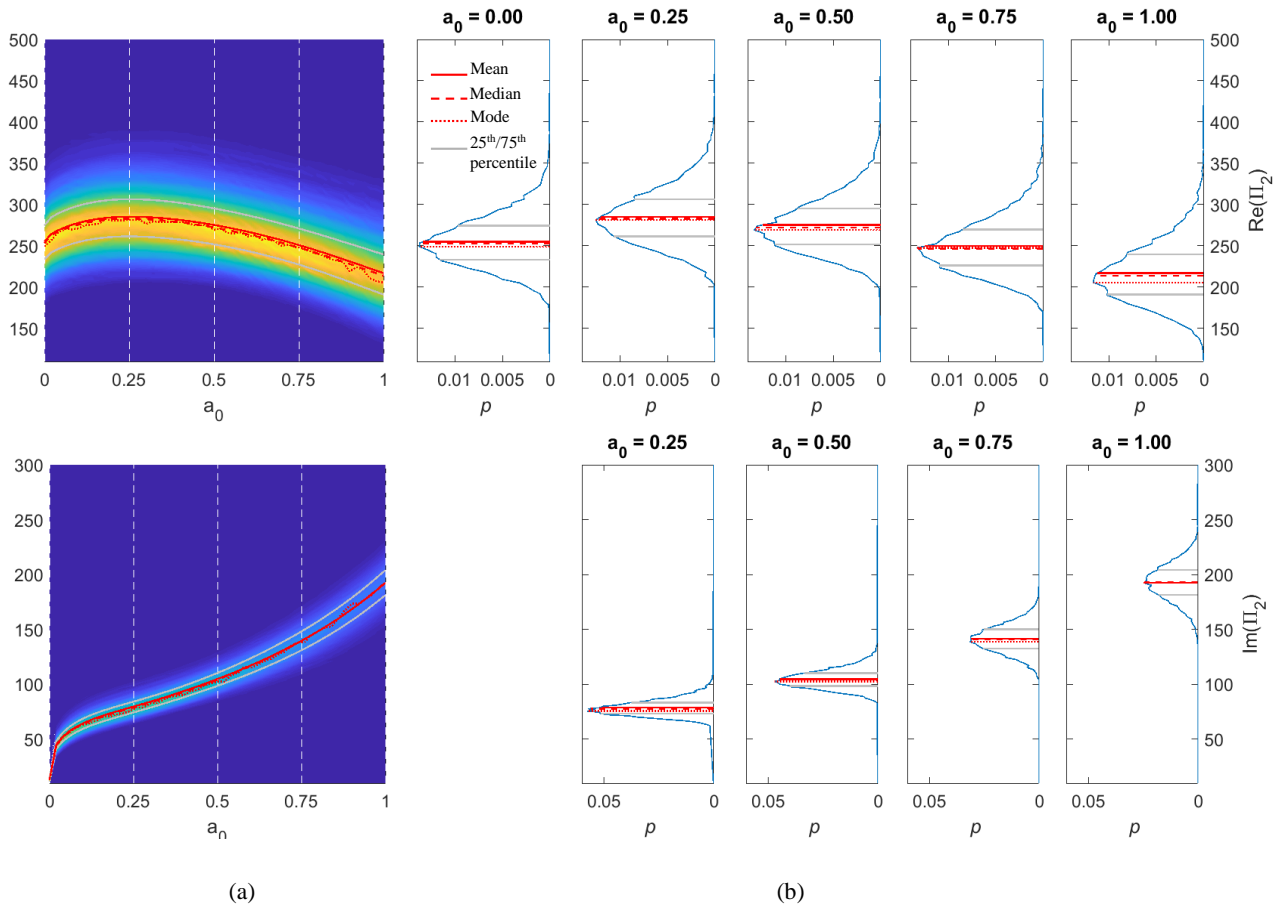

Figure 7. (a) Variability of Π_2 (real and imaginary parts) and (b) distributions of values at selected frequencies
Case 2x2, $s/d = 2$, $L/d = 8$, $V_s = 100$ m/s

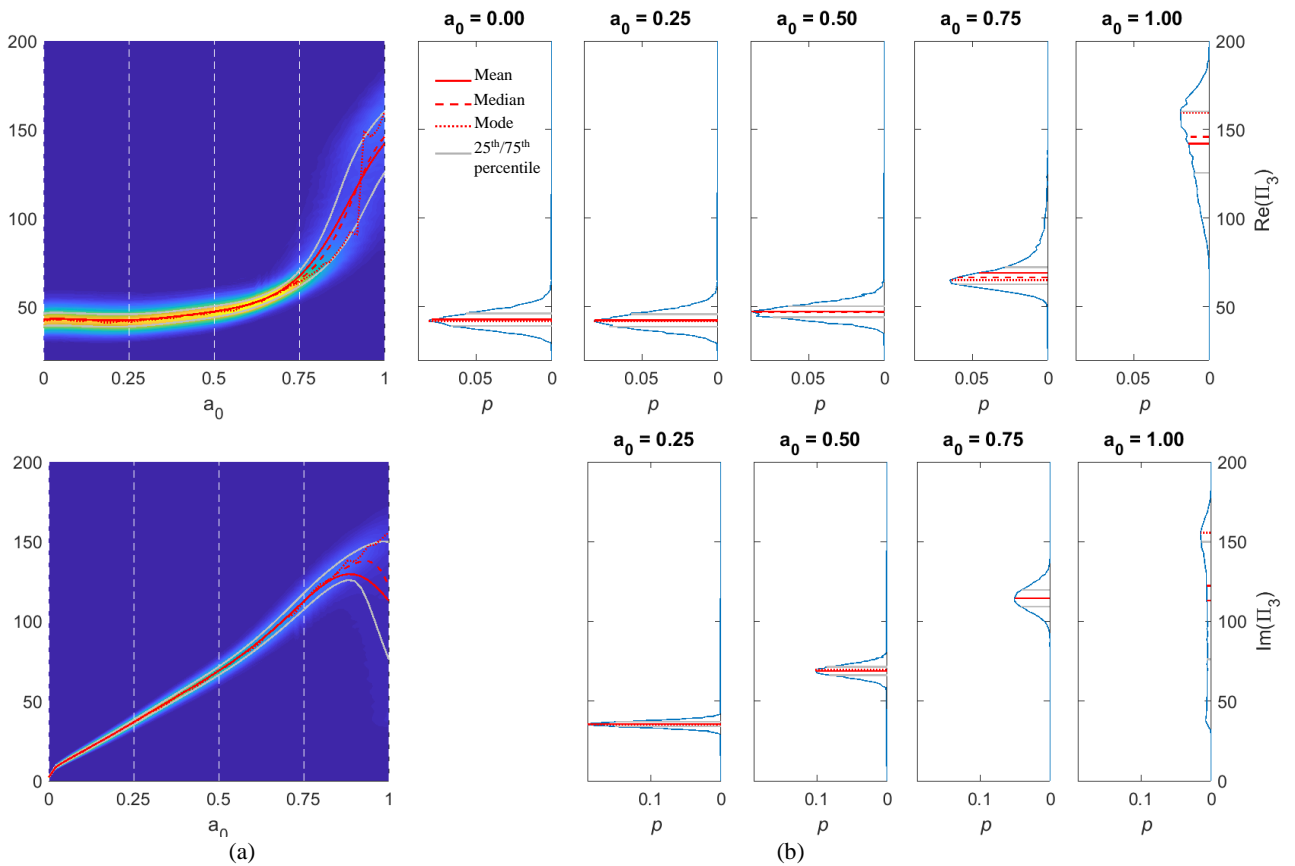

Figure 8. (a) Variability of Π_3 (real and imaginary parts) and (b) transverse distributions of values at selected frequency Case 3x3, $s/d = 4$, $L/d = 32$, $V_s = 200$ m/s

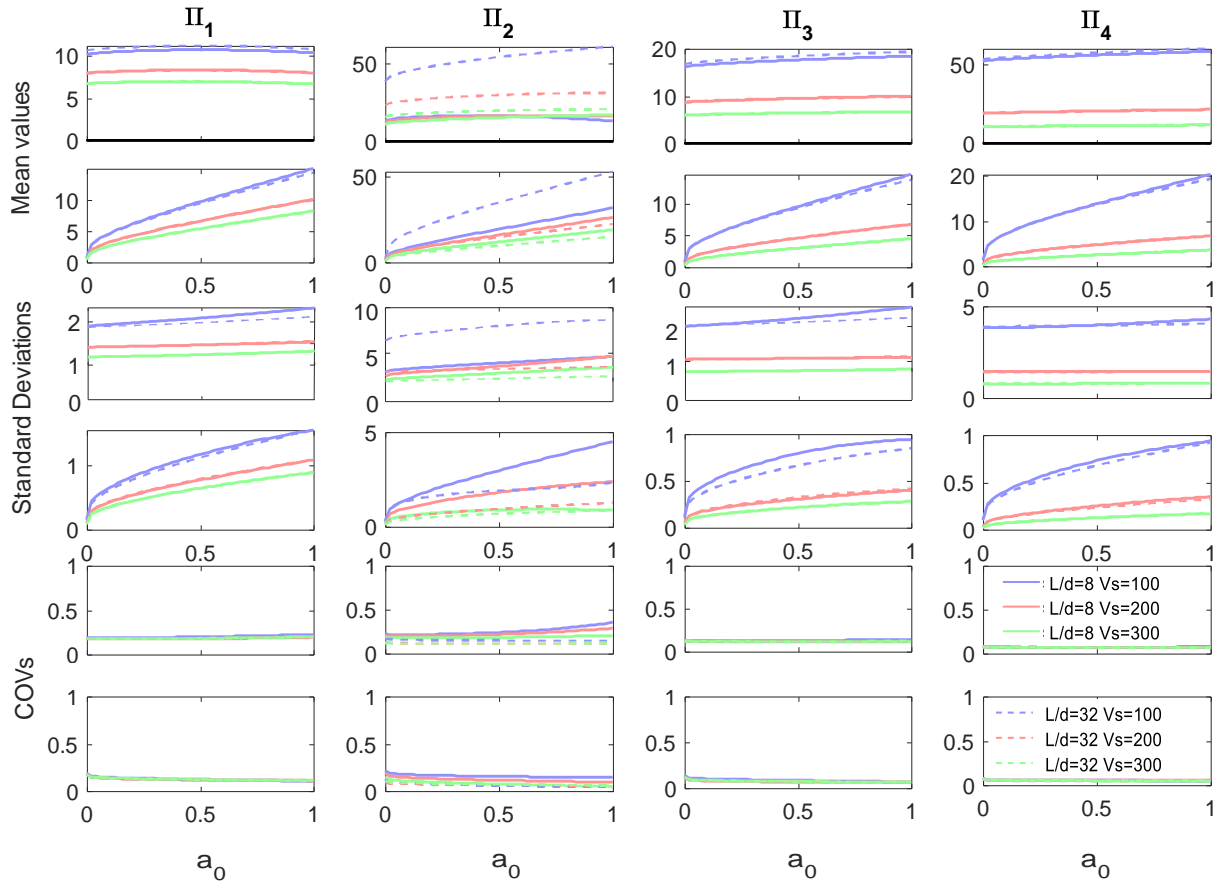

Figure 9. Frequency dependent mean values, standard deviations and COVs of real and imaginary parts of non-dimensional impedances of single piles

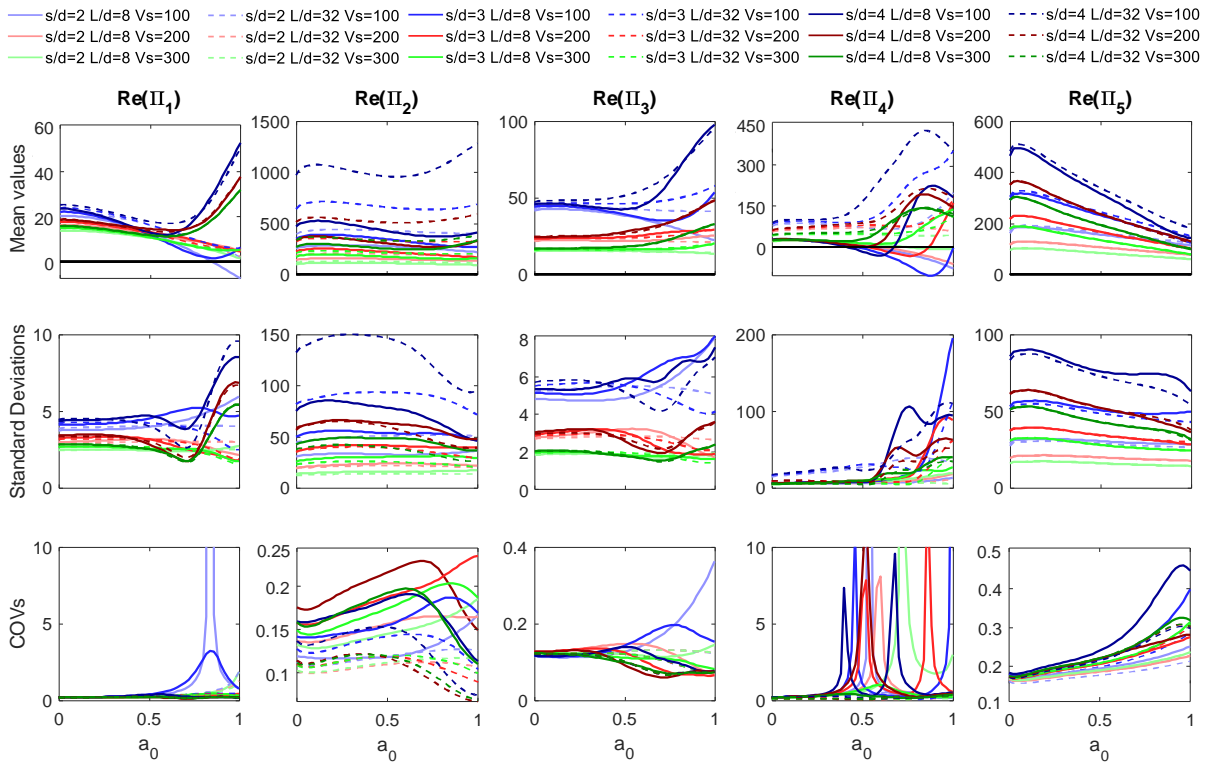

Figure 10. Frequency dependent mean values, standard deviations and COVs of real parts of non-dimensional impedances of 2x2 foundations

Figure 10 shows the frequency dependent mean values, standard deviations and the COVs of real part of the non-dimensional impedance functions of the 2x2 foundations. Effects of the s/d ratio and the soil stiffness on the mean values of impedances are thoroughly addressed in the literature [e.g., 5, 22, 24, 51-52]. Herein the variability and the scattering of results will be discussed: it can be observed that changes in the standard deviations are overall limited, particularly for the non-dimensional translational (Π_1) and vertical (Π_4) impedances for which COVs are within 15-20% up to a non-dimensional frequency of 0.5 and 0.3 for the translational and vertical components, respectively. For higher frequencies, COVs of both impedances are characterised by very high peaks due to the mean values approaching zero (resonance conditions); this phenomenon, which mainly affects foundations in soft soils for which the resonance condition occurs at lower frequencies, is important as uncertainties may reflect significantly on the response of the superstructure. The non-dimensional rotational impedance Π_2 and the coupled roto-translational impedance Π_3 are characterised by lower values of COVs in the whole frequency range, being within 25% and 40% respectively, with maximum values at higher frequencies ($a_0 > 0.5$). For Π_2 COVs of long piles are higher than those of short piles and increase with the s/d ratio. Finally, COVs of the torsional impedance Π_5 are the only one presenting a clear increasing trend with frequency passing from 10-20%, typical at lower frequencies, to 30-40% at higher frequencies.

Figure 11 shows quantities relevant to the imaginary components of impedances. Mean values show the typical increasing trend with frequency, characterised in some cases by peaks that for the highest s/d ratio fall within the investigated non-dimensional frequency range. Differently from mean values, standard deviations are almost constant in the frequency range 0-0.5 for all the impedance components (excepting for the static values, presenting very low standard deviations); for frequencies higher than 0.5, standard deviations increase rapidly and almost linearly with frequency. This feature produces the peculiar convex trends of the COVs, which decrease in the frequency range 0-0.5 and increase for higher frequencies. It is worth observing that COVs are included in the range 5-20% (up to 80% for the vertical component, only for $a_0 \geq 0.75$), excepting static or quasi-static values, which do not deserve attention since the mean values of imaginary parts of impedances tend to zero.

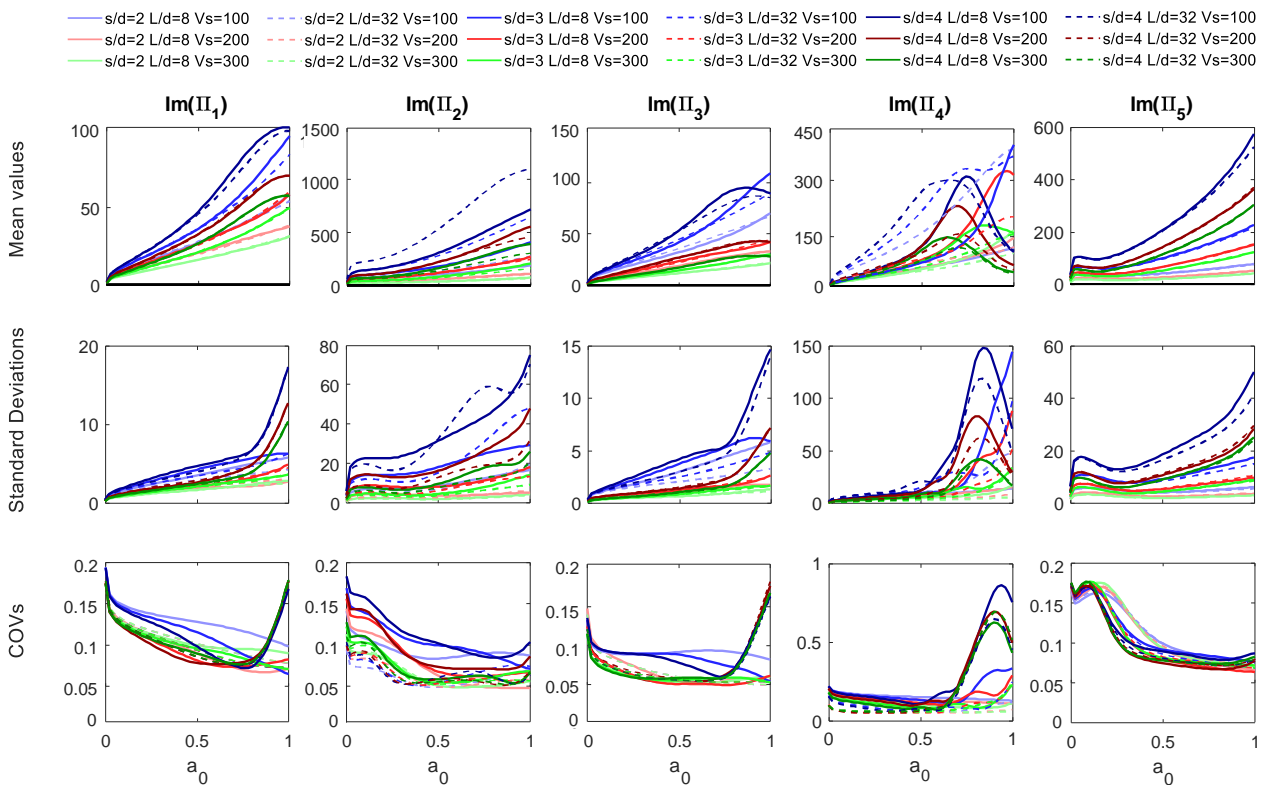

Figure 11. Frequency dependent mean values, standard deviations and COVs of imaginary parts of non-dimensional impedances of 2x2 foundations

With reference to the 3x3 foundations, Figure 12 shows the same quantities already presented. At a glance, similarities with results of the 2x2 foundations can be recognised. For example, standard deviations for the non-dimensional translational (Π_1) and vertical (Π_4) impedances are overall limited up to a non-dimensional frequency of 0.5 and 0.2 for the translational and vertical components, respectively. Again, at higher frequencies, COVs are characterised by peaks due to nearly null mean values; it is worth noting that these phenomena occur at lower frequencies with respect to 2x2 foundations and affect a higher number of investigated foundations. Trends of COVs (within 20%) of the non-dimensional rotational impedance Π_2 and the coupled roto-translational impedance Π_3 are similar to those observed for the 2x2 foundations (excluding cases producing peaks). Finally, differently from 2x2 foundations, COVs of torsional impedance Π_5 present a constant trend at 20% on the entire frequency range; previous considerations about the peaks hold.

Figure 13 shows quantities relevant to the imaginary components. In this case, similarities with results from 2x2 foundations can be found concerning trends of mean, standard deviations and COVs, but larger variations at higher frequencies ($a_0 > 0.5$) are evident on standard deviations and COVs of Π_2 and Π_3 , with maximum COVs two and three times higher than those of the 2x2 foundations, respectively.

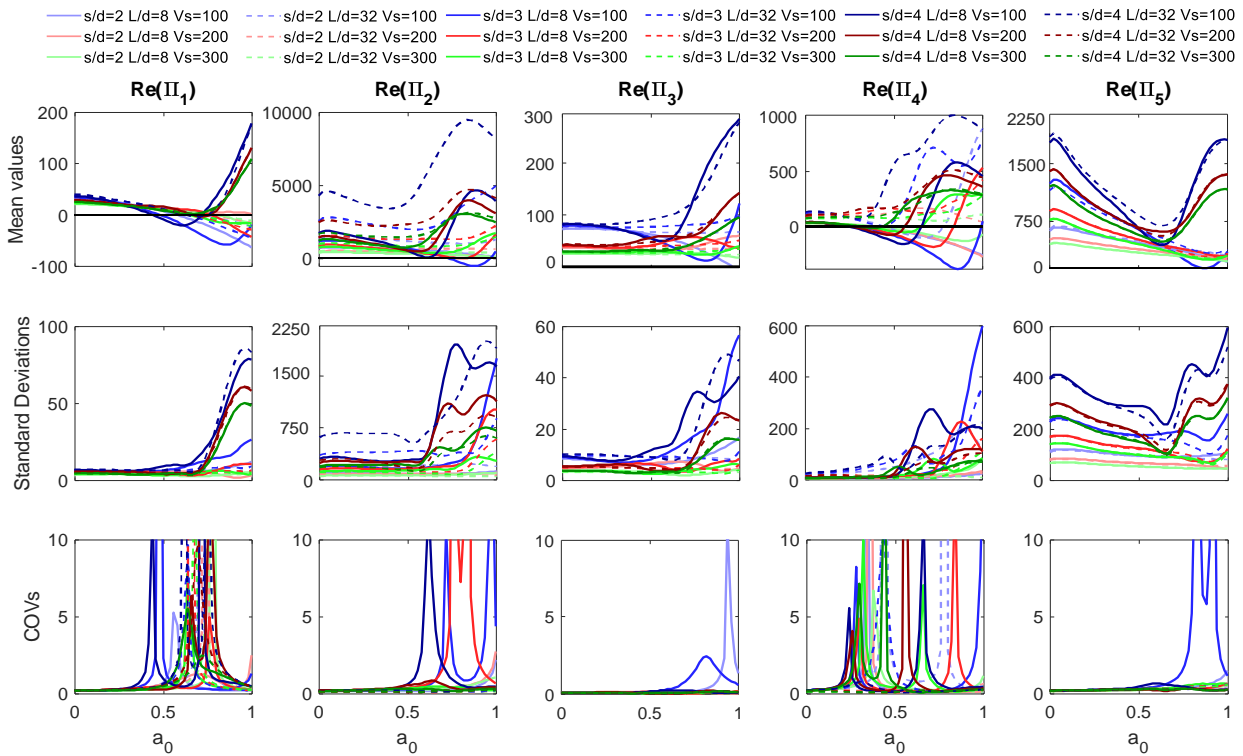

Figure 12. Frequency dependent mean values, standard deviations and COVs of real parts of non-dimensional impedances of 3x3 foundations

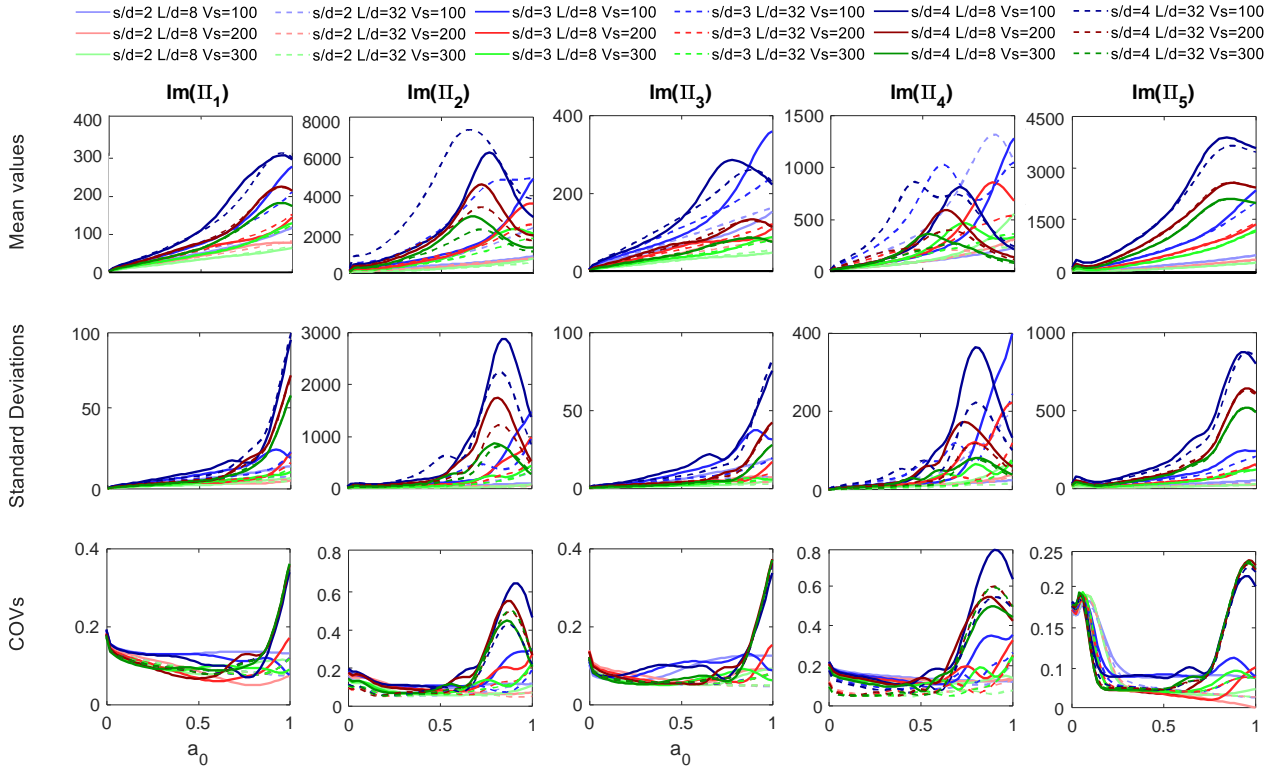

Figure 13. Frequency dependent mean values, standard deviations and COVs of imaginary parts of non-dimensional impedances of 3x3 foundations

4.1.1. Sensitivity indexes

In this section the first order sensitivity indexes \bar{S}_k for ρ_s , V_s and E_p are presented and discussed. Bar charts in

Table 3 collects the sensitivity indexes of all the single pile case studies. From an overall point of view, V_s is primarily responsible for the global variability of the results. Overall, for real parts sensitivity indexes of V_s are about 0.80 in all the considered pile configurations, expecting for the rotational component Π_2 , where the influence of the pile elastic modulus is similar to that of the shear wave velocity. This is because, differently from pile groups, the rotational stiffness of the single pile is strongly dependent on the pile elastic modulus (and the cross-section inertia properties). As for the imaginary parts, it can be observed that the sensitivity indexes of the soil density increase for the translational impedance Π_1 and the vertical impedance Π_4 ; V_s is no more the primarily responsible of the results variability. Also, the pile elastic modulus seems to play a significant role in the vertical impedance Π_4 (especially for long piles in soft soils) and a very important role for the rotational component Π_2 (with sensitivity indexes up to 0.8) for which, on the contrary, uncertainties on V_s have practically no implications on the results variability.

Bar charts in Table 4 and Table 5 depict the sensitivity indexes of 2x2 and 3x3 foundations. Comments on pile groups are provided together since they present similarities. Concerning real parts of impedances, for both 2x2 and 3x3 pile foundations, very high values of the V_s sensitivity indexes can be found for Π_1 and Π_5 for all the case studies (in the range 0.75-0.90), while Π_2 , Π_3 and Π_4 are slightly more sensitive to the effect of the other parameters variability, especially the soil density. The pile elastic modulus has a limited impact, mainly on the rotational (Π_2), coupled roto-translational (Π_3), and vertical (Π_4) components of the impedance matrix (the latter only in the case of long piles). As for imaginary parts, a different behaviour can be delineated; it is interesting to observe the overall higher influence of the soil density for all the impedance components; in detail, the sensitivity indexes of the soil density became comparable or even higher than those of the shear wave velocity, especially for the coupled roto-translational (Π_3) and torsional (Π_5) terms. Conversely, the variability of E_p scarcely contributes to the variability of the translation (Π_1) and torsional impedances (Π_5);

for the rotational (Π_2), the coupled roto-translational (Π_3) and the vertical (Π_4) impedances E_p sensitivity indexes up to 0.3 are observed in some cases.

Table 3: Sensitivity indexes for single piles.

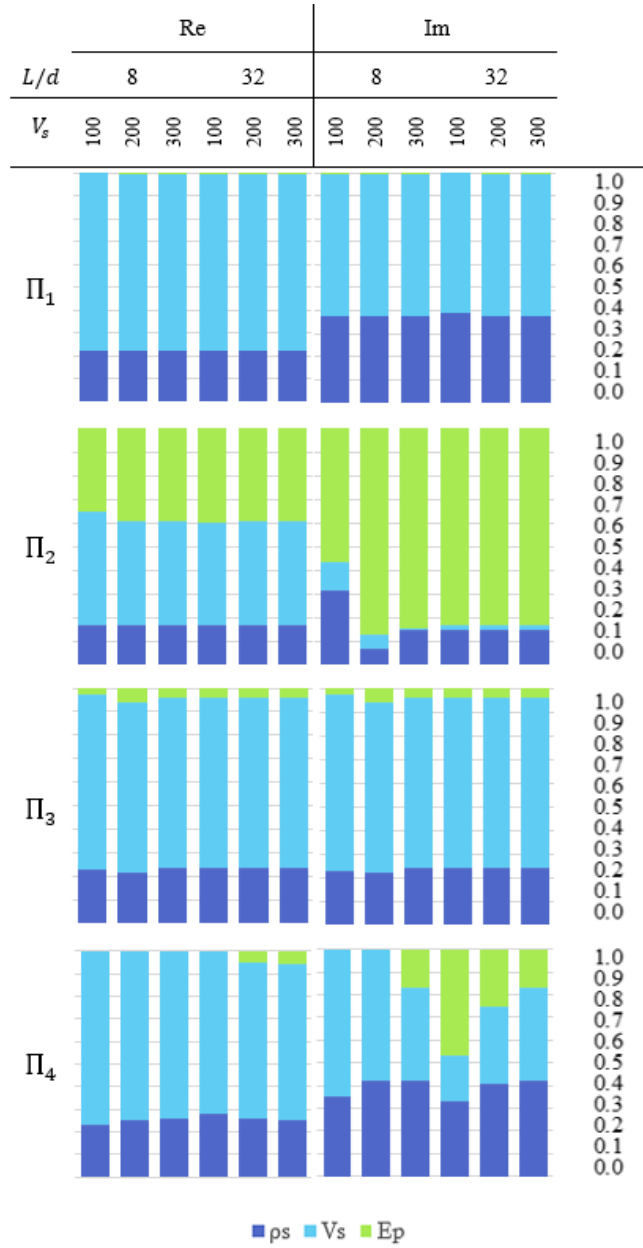

Table 4: Sensitivity indexes for 2x2 foundations.

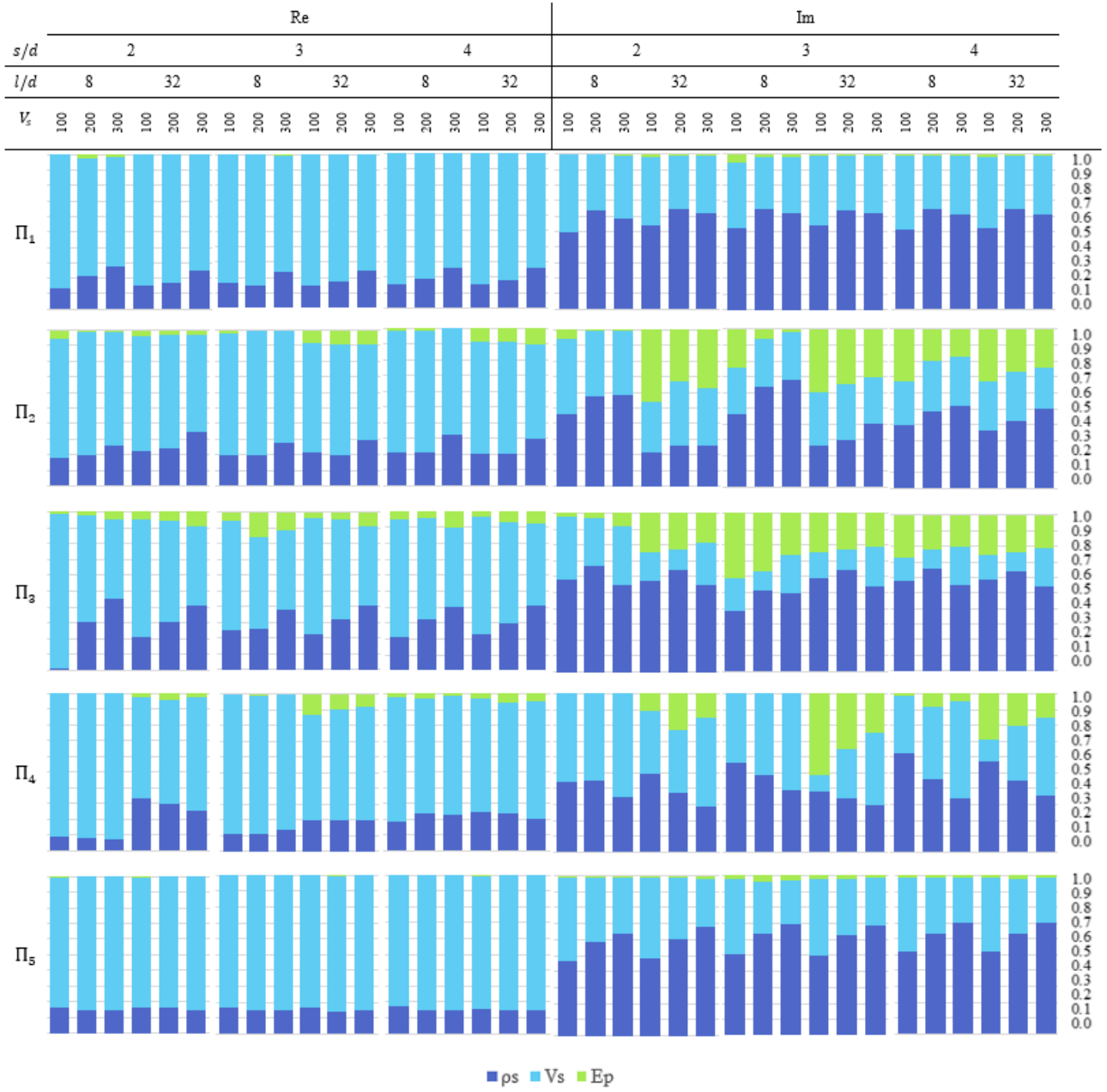
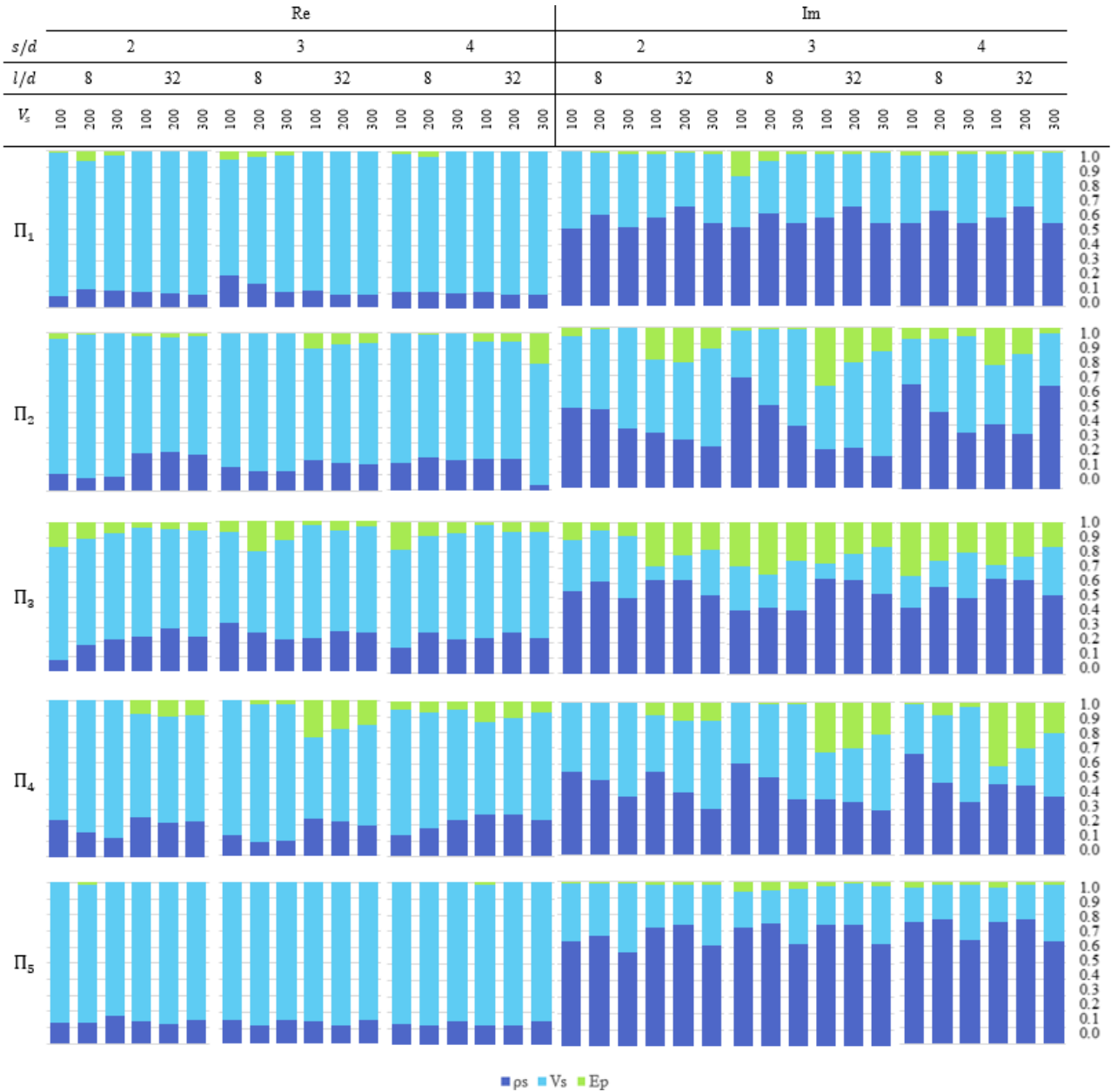

Table 5: Sensitivity indexes for 3x3 foundations.



4.2 Variability of kinematic response factors

In this section the variability of the Foundation Input Motion (FIM) given that of the random variables is addressed and discussed. Typical trends of the kinematic translational and rotational response factors are shown in Figure 14 for a set of samples from a 2x2 foundation layout (curves obtained from mean values of the probabilistic variables are in black line). Apart the very high variability of results, which will be addressed in the sequel, it can be observed that typical trends of the translational factor are characterised by a plateau of unit value extending up to a frequency that depends on the soil shear wave velocity (the higher the soil shear wave velocity, the higher the plateau extension is), followed by a rapid reduction and by a subsequent oscillation around a mean almost constant value. Furthermore, values greater than one 1 (up to 1.2) can be obtained for very stiff soils. On the contrary, the rotational kinematic response factor assumes nearly zero values at very low frequencies and increases rapidly with frequency presenting oscillations for higher frequencies, similarly to the translational parameter. Above trends, which are well known in the literature [53],

determine intrinsic difficulties in the identification of probabilistic models for the kinematic parameters since oscillations of curves, characterised by peaks shifted in frequency, produce density probability distributions with non-usual shapes, making the fitting with conventional probability density functions a non-sense.

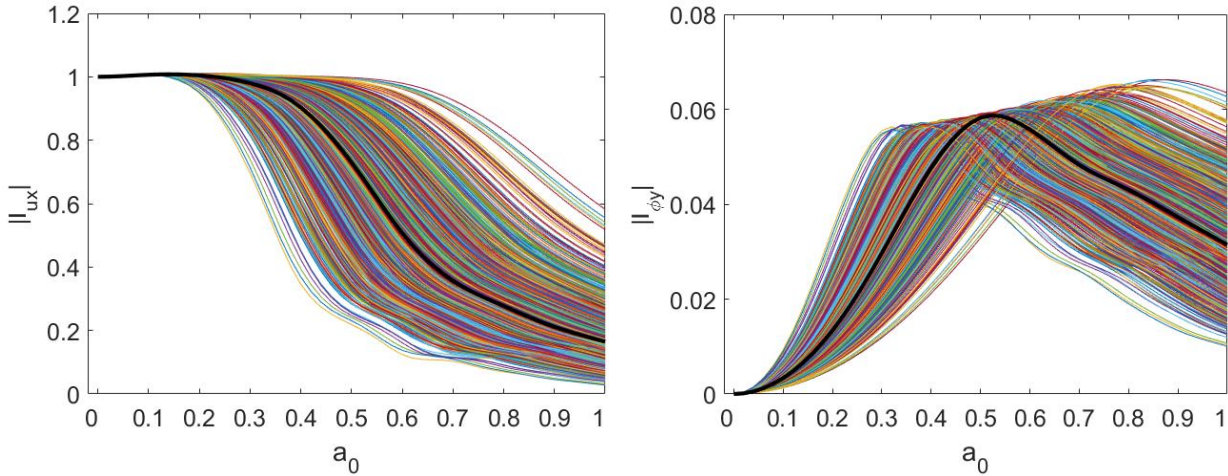

Figure 14. Typical trends of kinematic response factors (samples from case 2x2, $s/d = 4$, $L/d = 32$, $V_s = 100$ m/s). The black curves represent the kinematic response factors relative to the mean values of the sampling.

Results are presented adopting the approach used in the previous section for impedances. Figure 15 and Figure 16 show the variability of the translational (I_U) and rotational (I_Φ) kinematic response factors for two 2x2 and 3x3 foundations, being possible a generalization of comments concerning the main statistical parameters and the results scattering. Differently from impedances, a small range at low non-dimensional frequency (0-0.25) can be identified in which the results dispersion of the translational factor is almost negligible and the parameter can be described by its mean value; this is because, as already stated, at low frequencies the translational parameter is almost unitary. Overall, for $a_0 > 0.25$, the variability of I_U generally increases with frequency, consistently with the parameter decrement. This phenomenon, already observed for impedances, confirms that the higher the gradient of the curves with frequency, the higher the dispersion of the parameter is. The rotational kinematic response factor I_Φ also presents dispersions that follow the above rule. The density distributions at specific non-dimensional frequencies (0, 0.25, 0.50, 0.75 and 1.00), reported in Figure 15b and Figure 16b, confirm the dependence of the results scattering with the gradient of the function of the kinematic parameter. These phenomena are particularly evident for the 3x3 foundation where the mode of both the translational and rotational kinematic response factors presents jumps due to the strong variation of the data scattering with frequency, which is a consequence of the typical trends of the kinematic interaction parameters characterised by peaks (that naturally produces frequency ranges with high and low gradients of the kinematic response functions). Jumps in the mode values highlight that for certain frequencies the distributions can be bimodal with the most probable responses far from the mean one. Finally, the density distribution in Figure 15b and Figure 16b demonstrates the absence of a clear trend and the practical difficulty to define a probabilistic model for the parameter, at least for certain frequency ranges.

The first two statistical moments and the relevant COVs of the two kinematic response factors are discussed to provide a complete survey on the analysis results. Figure 17a refers to the investigated single piles; overall mean values present trends, with respect to V_s and L/d , that are well known from the technical literature and commenting about these goes beyond the aim of the paper. In contrast, it is worth discussing about COVs that, for the translational factor, remain constant with negligible oscillations around zero up to $a_0 = 0.4$, and then increase significantly and almost linearly with frequency with a gradient that depends on the shear wave velocity (the gradient reduces by increasing the soil shear wave velocity). Concerning the rotational parameters, mean values increase up to stabilise at $a_0 > 0.6$, 0.75 and 0.9 for $V_s = 100$, 200 and 300 m/s respectively, while standard deviations present an inflection point with an overall increasing trend in the whole frequency range. Consequently, COVs are characterised by a concave trend with the highest values ranging between 30-40%. It is both observing that above comments are in line with phenomena described in the previous paragraph for the two selected pile groups.

Figure 17b and Figure 17c, referring to 2x2 and 3x3 pile groups, respectively, are discussed together in view of their similarities in terms of results variability. Data relevant to the whole case studies confirm previous considerations: standard deviations of the translational kinematic response factors, and the relevant COVs, are very small in the low non-dimensional frequency range 0-0.25 while both increase for higher frequencies. With reference to the rotational factor, trends of standard deviations are quite similar to that of the mean values and COVs are almost constant with frequency, ranging between 10-40%.

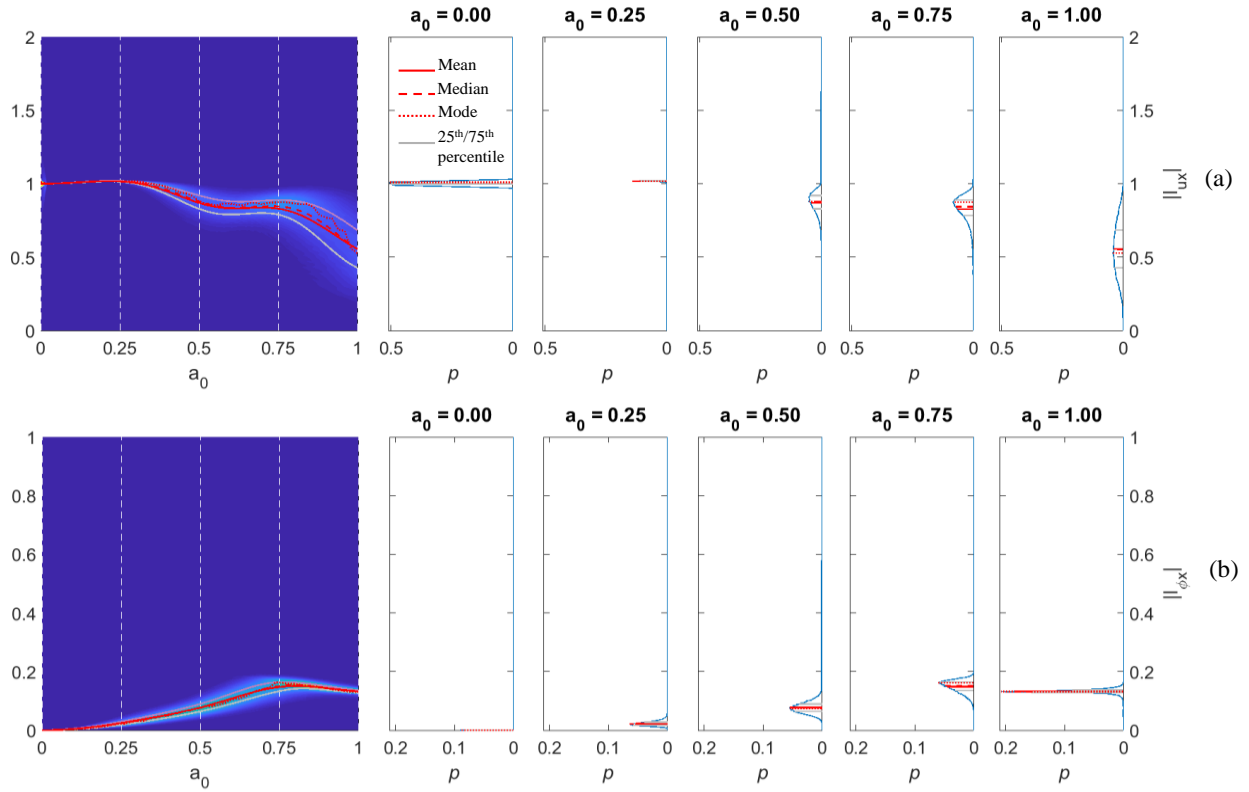

Figure 15. Variability of (a) I_U and (b) I_Φ for 2x2 foundation, $s/d = 3$, $L/d = 8$, $V_s = 200$ m/s

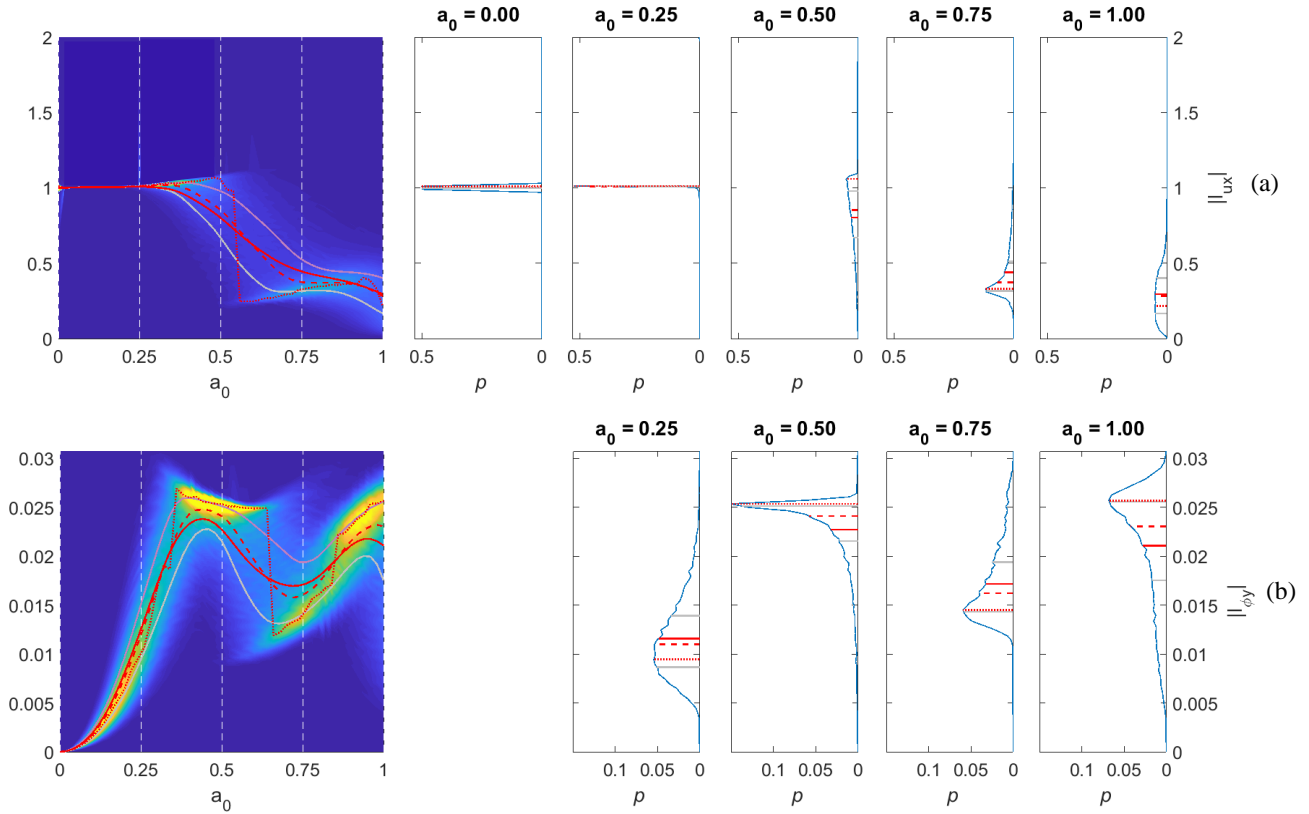

Figure 16. Variability of (a) I_U and (b) I_Φ for 3x3 foundation, $s/d = 4$, $L/d = 32$, $V_s = 100$ m/s

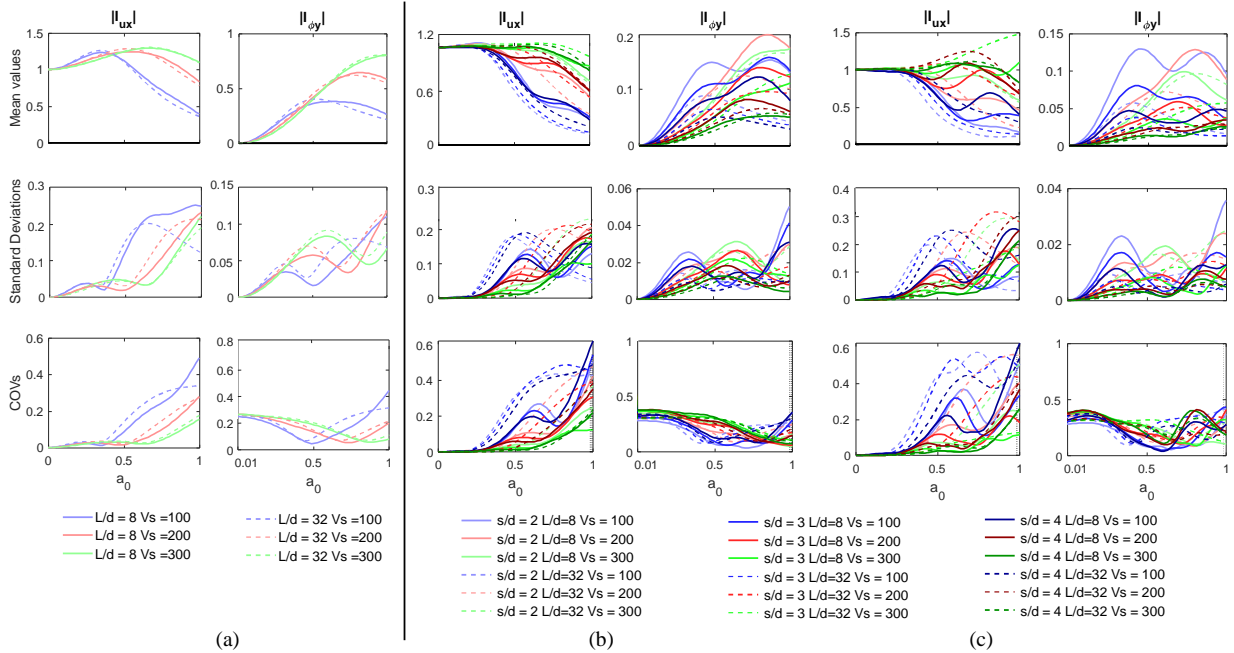

Figure 17. Frequency dependent mean values, standard deviations and COVs of FIM components of (a) single pile foundations, (b) 2x2 and (c) 3x3 pile group foundation

4.2.1. Sensitivity indexes

The first order sensitivity indexes \bar{S}_i for ρ_s , V_s and E_p are presented and discussed in this section. Bar charts in Table 6 collect the sensitivity indexes of all the investigated single piles. For both the kinematic response factors, the V_s is primarily responsible for the global variability of the results as demonstrated by the very high values of the sensitivity indexes (up to 0.95). Uncertainties in the soil density and the pile Young's modulus

have a negligible effect on the variability of the kinematic parameters. Bar charts in Table 7 refers to all the investigated pile groups foundations (2x2 and 3x3). Similarly to the single piles, the sensitivity indexes of V_s are very high, especially for the rotational kinematic response factor. In case of pile groups, a slightly higher effect of the soil density uncertainties is evident in the variability of the translational kinematic response factor, as documented by the sensitivity indexes of ρ_s , which for some cases are around 0.15.

Table 6: Sensitivity indexes for single piles' kinematic response factors.

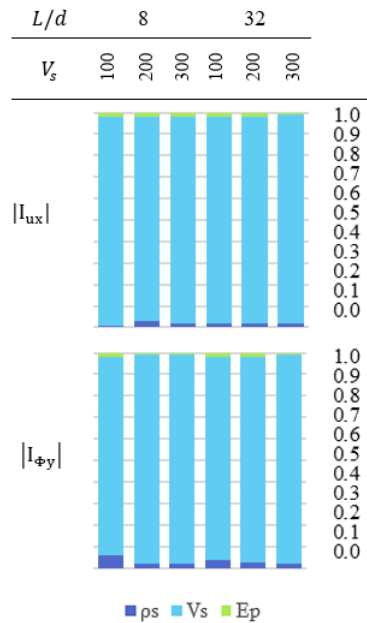
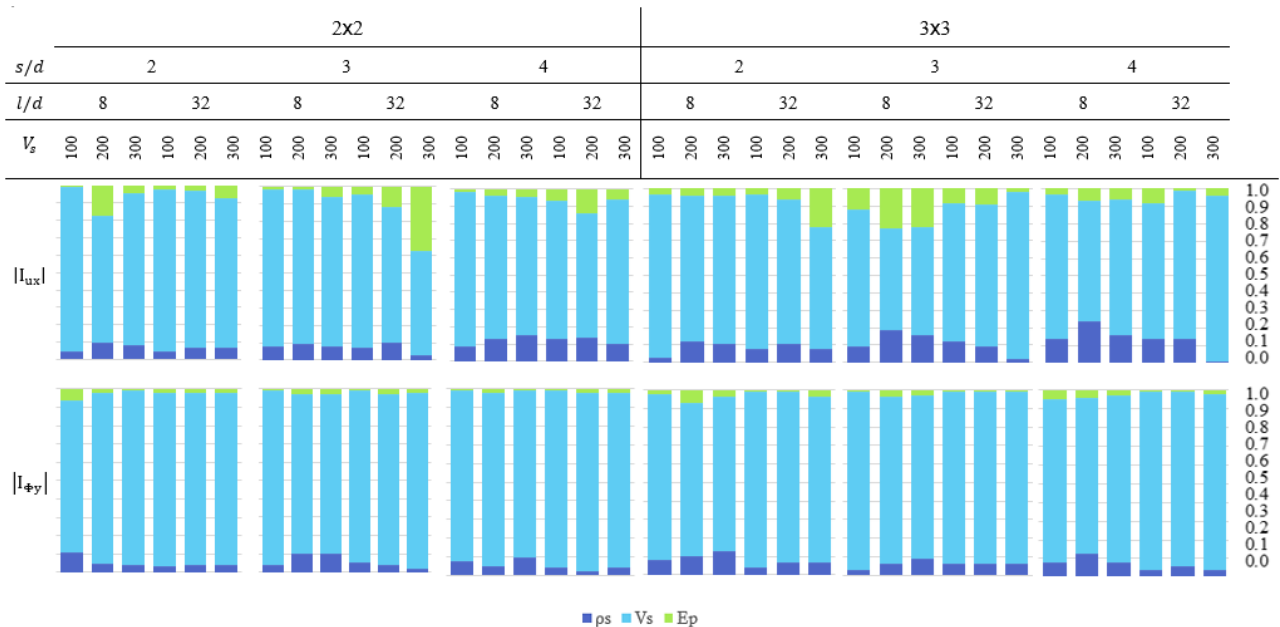

Table 7: Sensitivity indexes for pile group foundations' kinematic response factors.



5 CONCLUSIONS

In this paper a probabilistic investigation on the dynamic behaviour of pile foundations has been presented, with the purpose of addressing effects of intrinsic uncertainties of the main parameters governing the soil-piles interaction problem on the soil-foundation dynamic impedance and kinematic response factors. The soil density, the shear wave velocity and the concrete elastic modulus of piles are assumed as independent random variables and probabilistic distributions available in the literature are adopted to reproduce their uncertainties.

A Quasi-Random simulation technique is exploited to generate samples. Floating piles in homogeneous deposits are analysed considering different layouts and statistic parameters of the output quantities, derived from a total of 420000 cases, are presented and discussed.

The following main findings can be derived with respect to the variability of the soil-foundation impedances:

- probability distributions of impedances vary sensibly with frequency and, from an overall point of view, the data fitting with a unique known probability density function is not feasible.
- Scattering of results are higher for frequency ranges in which impedances are characterised by high gradients.
- Coefficients of variations highlight peaks for frequency ranges corresponding to the resonance of the soil-foundation system; this phenomenon suggests that impedance uncertainties are important since they may reflect significantly on the response of the superstructure, especially for those characterised by a fundamental period close to the resonance of the soil-foundation system.
- Sensitivity indexes reveal that the shear wave velocity is often mainly responsible for the global variability of the results; however, also uncertainties in the pile elastic modulus and the soil density may affect the results dispersions: as an example, the former is relevant for the rotational impedance of single piles, while the latter affects sensibly the imaginary parts of impedances of pile groups.

The following main conclusions can be drawn regarding the variability of the soil-foundation kinematic response factors:

- probability distributions of the parameters vary sensibly with frequency because of their peculiar trends, which makes the selection of a suitable distribution from those available in the literature a non-sense.
- Like for impedances, scattering of results are higher for frequency ranges in which impedances are characterised by high gradients.
- Sensitivity indexes reveal that the shear wave velocity is always the main variable affecting the global variability of the results.

Overall, uncertainties in the soil shear wave velocities are the most important ones and cannot be neglected in the probabilistic modelling of soil-foundation-superstructure systems, while uncertainties in the soil density and pile Young's modulus are often less important and may be disregarded in many practical cases. The probabilistic investigation clearly outlines that the variability of the dynamic response of single piles and pile groups is important, especially for higher frequency ranges, where both the frequency-dependent impedances and kinematic response factors are characterised by high gradients. It is worth observing that these phenomena occur at different frequencies depending on the foundation layout but are typical of all pile group foundations, and are almost independent on the model adopted for the analyses. Thus, although the widening of the foundation layouts is recommended, as well as the inclusion of stratified media, above conclusions may be assumed of general validity.

DECLARATIONS

Funding: the research is not supported by any funding.

Conflicts of interest: there are no conflict of interests.

Availability of data and material: data are available upon reasonable request from the corresponding author.

Code availability: codes are developed by the authors in Matlab environment [54].

REFERENCES

- [1] Lou M, Wang H, Chen X, Zhai Y. Structure–soil–structure interaction: Literature review. *Soil Dyn Earthq Eng* 2011; 31(12):1724-1731.
- [2] Stewart JP, Fenves GL, Seed RB. Seismic soil–structure-interaction in buildings I: analytical methods. *ASCE J Geotech Geoenviron Eng* 1999; 125(1):26–37.
- [3] Stewart JP, Fenves GL, Seed RB. Seismic soil–structure-interaction in buildings II: empirical findings. *ASCE J Geotech Geoenviron Eng* 1999; 125(1):38-48.
- [4] Aviles J, Perez-Rocha LE. Soil–structure interaction in yielding systems. *Earthq. Eng. Struct. Dyn.* 2003; 32(11):1749–71.
- [5] Mylonakis G, Nikolaou A, Gazetas G. Soil–pile–bridge seismic interaction: kinematic and inertial effects. Part I: soft soil. *Earthq Eng Struct Dyn* 1997; 26(3):337-359.
- [6] Sextos AG, Ptilakis KD, Kappos AJ. Inelastic dynamic analysis of RC bridges accounting for spatial variability of ground motion, site effects and soil–structure interaction phenomena. Part 1: Methodology and analytical tools. *Earthq Eng Struct Dyn* 2003; 32(4):607-627.
- [7] Carbonari S, Dezi F, Leoni, G. Linear soil–structure interaction of coupled wall–frame structures on pile foundations. *Soil Dyn Earthq Eng* 2011; 31(9):1296-1309.
- [8] Carbonari S, Morici M, Dezi F, Gara F, Leoni G. Soil-structure interaction effects in single bridge piers founded on inclined pile groups. *Soil Dyn Earthq Eng* 2017; 92:52-67.
- [9] Stefanidou SP, Sextos AG, Kotsoglou AN, Lesgidis N, Kappos AJ. Soil-structure interaction effects in analysis of seismic fragility of bridges using an intensity-based ground motion selection procedure. *Eng Struct* 2017; 151:366-80
- [10] Carbonari S, Dezi F, Leoni G. Seismic soil-structure interaction in multi-span bridges: application to a railway bridge. *Earthq Eng Struct Dyn* 2011; 40(11):1219-1239.
- [11] Mylonakis G, Gazetas G. Seismic soil-structure interaction: beneficial or detrimental? *J Earthq Eng* 2000; 4(3):277-301.
- [12] Wolf JP. *Dynamic soil–structure interaction*. New Jersey: Prentice-Hall; 1985.
- [13] Sextos AG, Ptilakis KD, Kappos AJ. Inelastic dynamic analysis of RC bridges accounting for spatial variability of ground motion, site effects and soil- structure interaction phenomena. Part 2: parametric study. *Earthq Eng Struct Dyn* 2003; 32(4):629-652.
- [14] Lutes LD, Sarkani S, Jin S. Response variability of an SSI system with uncertain structural and soil properties. *Eng Struct* 2000; 22(6):605-620.
- [15] Cottureau R, Clouteau D, Soize C. Construction of a probabilistic model for impedance matrices. *Computer Methods in Applied Mechanics and Engineering* 2007; 196(17–20):2252-2268.
- [16] Soize C. A nonparametric model of random uncertainties for reduced matrix models in structural dynamics. *Prob. Engrg. Mech.* 2000;15: 277-294.
- [17] Soize C. Maximum entropy approach for modeling random uncertainties in transient elastodynamics. *J. Acoust. Soc. Am.* 2001;109(5): 1979-1996.
- [18] Moghaddasi M, Cubrinovski M, Chase JG, Pampanin S, Carr A. Probabilistic evaluation of soil-foundation-structure interaction effects on seismic structural response. *Earthq Eng Struct Dyn* 2011; 40(2):135-154.
- [19] Sobol' IM, Turchaninov VI, Levitan YL, Shukhman BV. *Quasirandom sequence generators*. Institute of Applied Mathematics, Russian Academy of Sciences, Moscow; 1992.
- [20] Dezi F, Carbonari S, Leoni G. A model for the 3D kinematic interaction analysis of pile groups in layered soils. *Earthq Eng Struct Dyn* 2009; 38(11):1281-1305.
- [21] Álamo GM, Martínez- Castro AE, Padrón LA, Aznárez JJ, Gallego R, Maeso O. Efficient numerical model for the computation of impedance functions of inclined pile groups in layered soils. *Eng Struct* 2016; 126:379- 390.

- [22] Dezi F, Carbonari S, Morici M. A numerical model for the dynamic analysis of inclined pile groups. *Earthq Eng Struct Dyn* 2015; 45(1):45- 68.
- [23] Padrón LA, Aznárez JJ, Maeso O. BEM–FEM coupling model for the dynamic analysis of piles and pile groups. *Eng Anal Bound Elem* 2007; 31(6):473- 484.
- [24] Dobry R, Gazetas G. Simple method for dynamic stiffness and damping of floating pile groups. *Geotechnique* 1988; 38(4):557- 574.
- [25] Gazetas G, Dobry R. Horizontal response of piles in layered soil. *J Geotech Eng* 1984; 110(1):20- 34.
- [26] Dobry R, Vicente E, O'Rourke MJ, Roesset JM. Horizontal stiffness and damping of single piles. *J Geotech Eng Div ASCE* 1982; 108(GT3):439-59.
- [27] Makris N, Gazetas G. Displacement phase differences in a harmonically oscillating pile. *Geotechnique* 1993; 43(1):135-50.
- [28] Gazetas G, Dobry R. Simple radiation damping model for piles and footings. *J Eng Mech ASCE* 1984; 110(6):937-56.
- [29] Makris N, Gazetas G. Dynamic pile–soil–pile interaction. Part II: lateral and seismic response. *Earthq Eng Struct Dyn* 1992; 21(2):145-162.
- [30] Mylonakis G, Gazetas G. Vertical vibration and additional distress of grouped piles in layered soil. *Soils and Foundations* 1998; 38(1):1-14.
- [31] Capatti MC, Carbonari S, Dezi F, Gara F, Leoni G. Validation of a 3D model for dynamic soil-structure-interaction of pile foundations by means of in situ tests. In *Atti del XVII Convegno ANIDIS L'ingegneria Sismica in Italia: Pistoia, 17-21 settembre 2017*; 68-77.
- [32] Dezi F, Roia D, Capatti MC, Carbonari S, Gara F, Leoni G, Morici M. Evaluation of dynamic soil-pile interaction based on both full scale in situ tests and numerical simulations. In *7th International Conference on Earthquake Geotechnical Engineering (ICEGE) 2019*; CRC Press.
- [33] Phoon KK, Kulhawy FH. Evaluation of geotechnical property variability. *Canadian Geotechnical Journal* 1999; 36(4):625-639.
- [34] Phoon K, Nadim F, Uzielli M, Lacasse S. Soil variability analysis for geotechnical practice. In *Characterisation and Engineering Properties of Natural Soils 2006*; Taylor Francis.
- [35] Mayne PW, Coop MR, Springman S, Huang AB, Zornberg J. State-of-the-Art Paper (SOA-1): GeoMaterial Behavior and Testing. In *Proc. 17th Intl. Conf. Soil Mechanics & Geotechnical Engineering 2009*; 4:2777-2872.
- [36] Bartlett FM, MacGregor JG. Statistical analysis of the compressive strength of concrete in structures. *ACI Mater J* 1996; 93(2):158–68.
- [37] Nielson, BG. Analytical fragility curves for highway bridges in moderate seismic zones. *Georgia Institute of Technology*; 2005.
- [38] Stefanidou SP, Kappos AJ. (2017). Methodology for the development of bridge- specific fragility curves. *Earthq Eng Struct Dyn* 2017; 46(1):73-93.
- [39] Jones AL, Kramer SL, Arduino P. Estimation of uncertainty in geotechnical properties for performance-based earthquake engineering. Technical Report 2002/16, Pacific Earthquake Engineering Research Center, PEER, Univ. of California at Berkeley, Berkeley, Calif., 2002.
- [40] Moon SW, Ku T. Empirical estimation of soil unit weight and undrained shear strength from shear wave velocity measurements. In *Proceedings, 5th International Conference on Geotechnical and Geophysical Site Characterization (ISC'5)*. Australian Geomechanics Society 2016; 2:1247-1252.
- [41] Griffiths, S. C., Cox, B. R., Rathje, E. M., & Teague, D. P. (2016). Surface-wave dispersion approach for evaluating statistical models that account for shear-wave velocity uncertainty. *Journal of Geotechnical and Geoenvironmental Engineering*, 142(11), 04016061.

- [42] CNR. Guide for the probabilistic assessment of the seismic safety of existing buildings. Report CNR-DT 212/2013, CNR – Advisory Committee on Technical Recommendations for Construction, Rome; 2014.
- [43] EN1992-1-1:2004 Eurocode 2: Design of concrete structures - Part 1-1: General rules and rules for buildings.
- [44] Jin S, Lutes LD, Sarkani S. Response variability for a structure with soil–structure interactions and uncertain soil properties. *Probabilistic Engineering Mechanics* 2000; 15(2):175-183.
- [45] Saltelli A, Tarantola S, Campolongo F, Ratto M. *Sensitivity analysis in practice: a guide to assessing scientific models*. Chichester, England; 2004.
- [46] Saltelli A, Ratto M, Andres T, Campolongo F, Cariboni J, Gatelli D, Saisana M, Tarantola, S. *Global sensitivity analysis: the primer*. John Wiley & Sons; 2008.
- [47] Saltelli A, Annoni P, Azzini I, Campolongo F, Ratto M, Tarantola S. Variance based sensitivity analysis of model output. Design and estimator for the total sensitivity index. *Computer Physics Communications* 2010; 181(2):259-270.
- [48] Rubinstein RY, Kroese DP. *Simulation and the Monte Carlo method*. Vol. 10, John Wiley & Sons, 2016.
- [49] Minnucci L, Dezi F, Carbonari S, Morici M, Gara F, Leoni G. Effects of uncertainties of soil and pile mechanical properties on the dynamic stiffness of single piles in homogenous deposits. In 7th International Conference on Computational Methods in Structural Dynamics and Earthquake Engineering (COMPDYN) 2018.
- [50] El-Marsafawi. *Dynamic analysis of single piles and pile groups* (Doctoral dissertation, University of Western Ontario), November 1993.
- [51] Carbonari S, Morici M, Dezi F, Leoni G. Analytical evaluation of impedances and kinematic response of inclined piles. *Eng Struct* 2016; 117:384-396.
- [52] Kaynia AM. *Dynamic stiffness and seismic response of pile groups* (Doctoral dissertation, Massachusetts Institute of technology), January 1982.
- [53] Fan K, Gazetas G, Kaynia A, Kausel E, Ahmad S. (1991). Kinematic seismic response of single piles and pile groups. *J Geotech Eng* 1991; 117(12):1860-1879.
- [54] MATLAB 2020b, The MathWorks, Inc., Natick, Massachusetts, United States.

Reply to Reviewers

[Click here to view linked References](#)

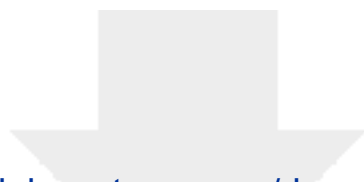

Click here to access/download
attachment to manuscript
Reply_to_Reviewers.doc

